

Planning Guide / Product Range

Systems in Balance

Ventilating and Bleed Valve type 591
Ventilating Valve type 595



General

Optimal venting of your system

Ventilating and bleed valves regulate the exchange of air or gas in piping systems and allow your system to breathe easy

With ventilating and bleed valves, gas in tanks and piping systems can be removed, or alternatively they can be aerated to prevent a vacuum automatically and without the use of external energy.

The valves are designed differently depending on the specific venting requirements. GF Piping Systems offers valves for exhausting air which enters the pipes and tanks during filling and for admitting air during the emptying process.

ATTENTION!

A closed valve under operating pressure cannot vent!

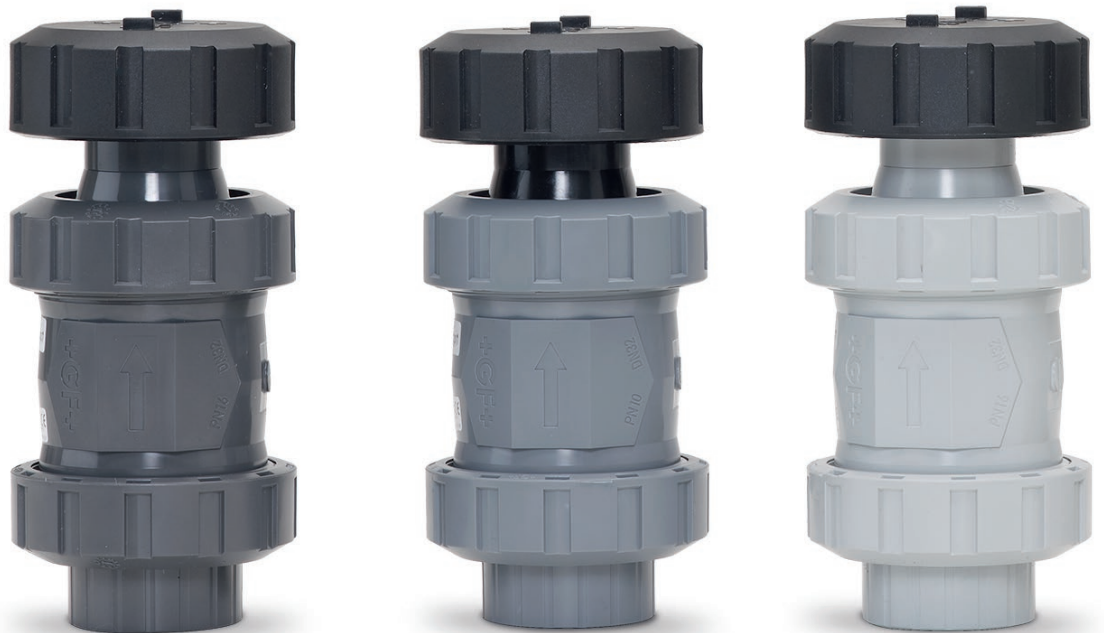

Gases in the system

Ensure the safety and durability of your system thanks to controlled ventilating and bleeding – easily and economically.

Air accumulation in piping systems and vessels

Piping systems need to be free of air for optimal operating conditions. Air accumulation in the piping system can lead to dynamic pressure changes as a result of the different densities of the media and generally occurs at points in the pipeline with a lower operating pressure than in the surrounding sections.

Causes of air accumulation

During operation, dissolved air can be released by pumps, valves, fittings and other piping components, causing air to accumulate in the pipeline.

When filling vessels, tanks and pipelines or when servicing these, air can be admitted to the system. Also when dissolved air is outgassed from the medium during temperature and pressure fluctuations, excess air can be created in the system.

Effects of air accumulation

Air or gases in the system have significant negative effects on the entire installation.

- Flow reduction due to a restriction of the flow cross-section
- Pressure loss
- Dynamic pressure changes & water hammer
- Threat to the structural safety of the pipeline
- Distortion of flow volume measurements
- Damage to flow measurement devices
- Vibrations > damage to valves
- Dry running of pumps

Causes of negative pressure

Particularly at risk for a negative pressure forming in the piping system are the highest geodetic and hydraulic points in the pipeline. Discontinuities in the liquid column can create cavitation and mainly occur behind downstream from throttle points, line valves, pumps or turbines.

Switching off pumps, rapidly opening or closing valves or draining the pipeline (or just sections) can lead to water hammer and consequently also damages the pipeline, e.g. causing pipes to leak or burst. When operation of control and regulating valves is interrupted, negative pressure can also develop in the system.

Effects of negative pressure

Negative pressure or a vacuum can seriously damage a system.

- Damage to pipelines, tanks and medium-conveying components
- Increased incrustation due to suction effect
- Dislodged incrustation > valve blockage
- Break in the water column (incorrect measurement results, etc.)
- Pumps running dry



Function

Effective aeration and deaeration – a must

Protect your system

Functionality type 591

Deaerate when filling – aerate when emptying

The combination Ventilating and Bleed Valve type 591 from GF Piping Systems ensures complete and reliable aerating and deaerating of a tank or a pipeline and simultaneously serves as overflow protection. Depending on the filling speed, the float is lifted by the rising level of the liquid. At the same time, gases are removed from the system through the valve. When the pipeline or the storage tank is completely full, the float is pressed into the profile seal and closes the valve. The system is now completely deaerated. When the liquid sinks as a result of draining, the valve automatically opens again and air can flow in.

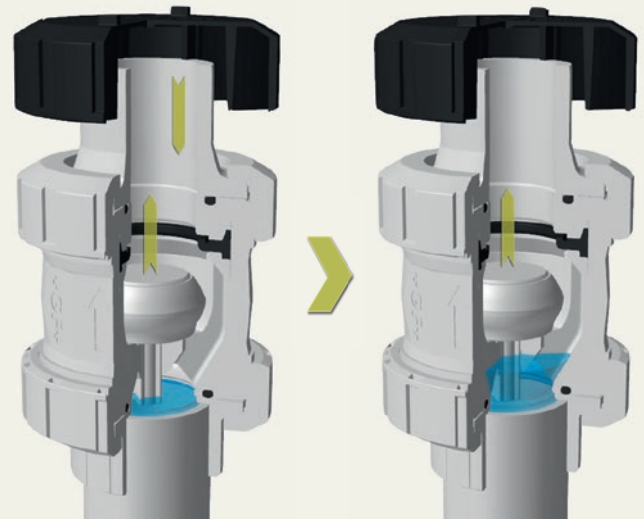

Valve open

Float rises when filling > deaerate

Functionality type 595

Aerate when draining

The Ventilating Valve type 595 was specially designed for the aerating process and is used wherever a safe and controlled air supply needs to be ensured. Gases/liquids are thus safely prevented from escaping to the environment (e.g. applications in the scope of the Federal Emissions Control Act / TA Luft 2 (technical regulations on air quality)).

The cone is pressed continually into the profile seal by the spring and only opens when there is negative pressure in the pipeline or the tank. The 595 valve allows the required volume of air to flow, thus equalizing the pressure and preventing negative pressure and the associated damages from occurring. Subsequently, the valve closes again by spring force.

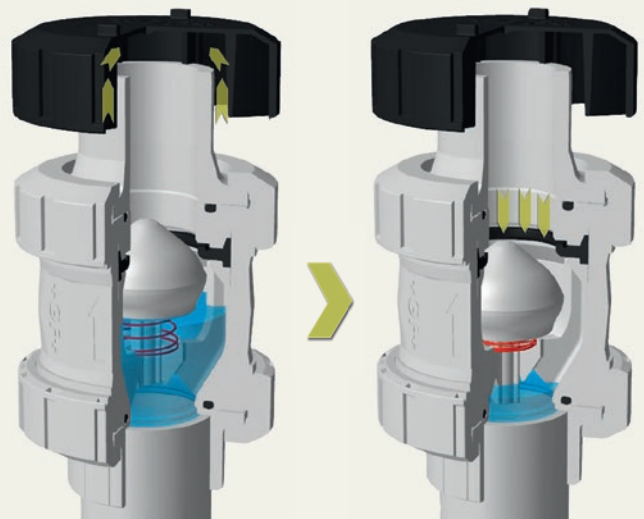

Valve closed by spring force

Draining produces a negative pressure

Benefits of ventilating and bleed valves

The new ventilating and bleed valves feature a unique design – uniting innovation with efficiency.

The compelling features of GF Piping Systems Ventilating and Bleed Valves type 591 and 595 are the easy installation and compact design – focused on safety, ergonomics and operating efficiency.

The wide selection of materials, seals and dimensions allows using the valves in diverse types of environments and installing them in any desired system. Thanks to an innovative geometry, the valves from GF Piping Systems offer even more efficiency and precision and protect your systems in the following ways:

- Low investment costs
- Low total cost of ownership
- Long lifetime of valves
- Excellent chemical resistance – even with aggressive media
- Large variety of materials for numerous types of applications
- Customized configurations
- Large offering of suitable shut-off valves, special sets and piping components > one-stop shopping

Thanks to the comprehensive product range, the 591 and 595 valves are suitable for all conventional plastic piping systems – worldwide.

* ATTENTION!

Valve only vents automatically in unpressurized systems!

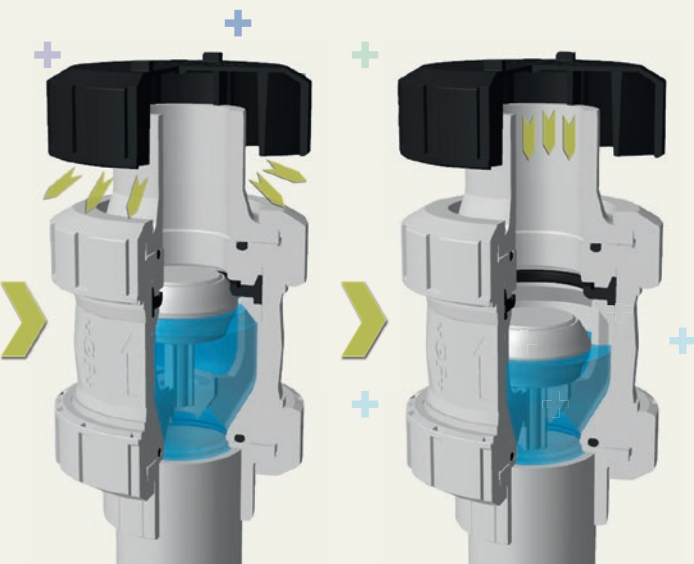

Valve closed and sealed tight

* Float sinks when draining > aerate

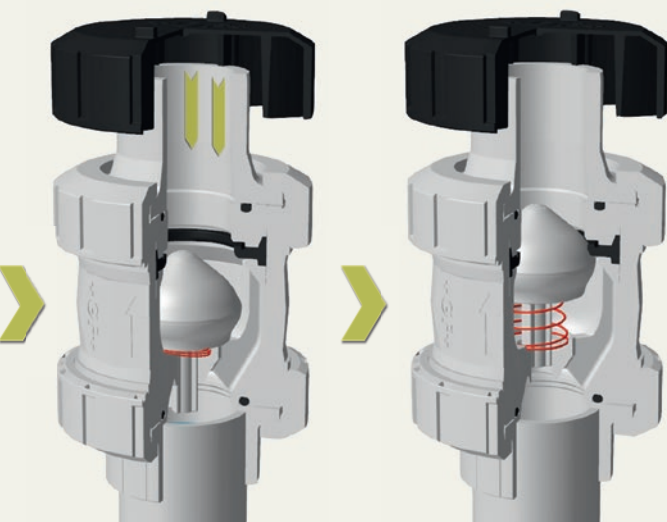

Valve opens, air flows in

Valve closes after pressure has been equalized

Installation

The right product, professionally installed

Safe operation with a professional installation

The instructions in the operating manual, operational safety and general safety regulations as well as the relevant norms and guidelines must always be observed.

The valves may only be operated in the indicated pressure and temperature range:

- The ventilating and bleed valve must always be built in vertically
- The right dimensioning is a prerequisite
- The valves are installed at the highest point of the system – where gases accumulate
- Fill slowly, because filling too fast can cause liquids to leak through the ventilating and bleed valve
- The valve should be easily accessible for operating, functionality checks and maintenance work

Installation in pipelines

If the system is filled too rapidly, the medium could spill over due to the cone's inertia.

We therefore recommend always installing a shut-off valve (e.g. BV 546) upstream of the ventilating and bleed valve. By opening the valve slowly, the venting speed can be controlled manually and overflow prevented.

Also, with a closed ball valve, installing and removing the valve or function testing is always possible without having to shut down operation.

In addition to a shut-off valve, an adequately dimensioned ventilation dome is important for correct valve installation. If not specified in detail, it should correspond in height to the diameter of the pipeline. The nominal diameter of the dome should be approximately half of the pipe cross-section.



Tender specifications

Ventilating and bleed valves

Ventilating and bleed valves should be available in the dimensions DN10-100 and have a pressure rating of PN10/PN16. They should be equipped with a PP-H float having a density of 0.91g/cm^3 .

All ventilating valves should be available in the dimensions DN10-100 and have a pressure rating of PN16. They should be equipped with a plastic-coated stainless steel spring and should have a minimum opening pressure of 10-80 mbar.

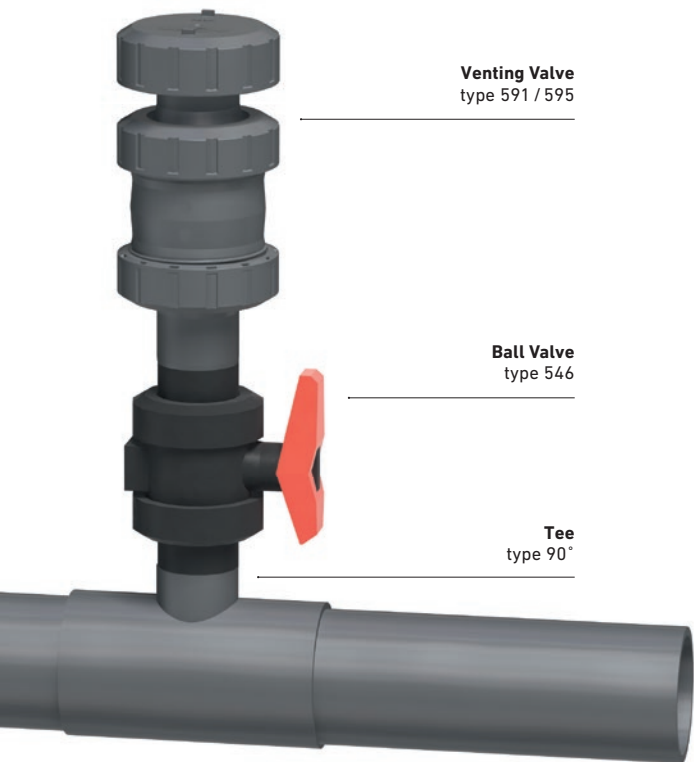

Example

Pipeline: d50
 Height of ventilation dome: ca. 50 mm
 Nominal diameter ventilation dome: d25

Product details

Material of valve body	PVC-U, PVC-C, ABS, PP-H, PVDF
Dimensions	d16DN10 - d110DN100, $\frac{3}{8}$ " - 4"
Pressure ratings	PVC-U, PVC-C, PVDF: PN 16 PP-H, ABS: PN10
Connections	Solvent cement sockets ISO, BS, ASTM/ANSI, JIS Solvent cement spigots ISO Threaded sockets
Sealing materials	EPDM, FPM, FFPM
Float materials	PP-H, PVDF
Spring material for type 595	Standard: V2A, Nimonic Optional: V2A Halar coated
Approvals	ACS, DIBt, FDA TA-Luft, NAMSA

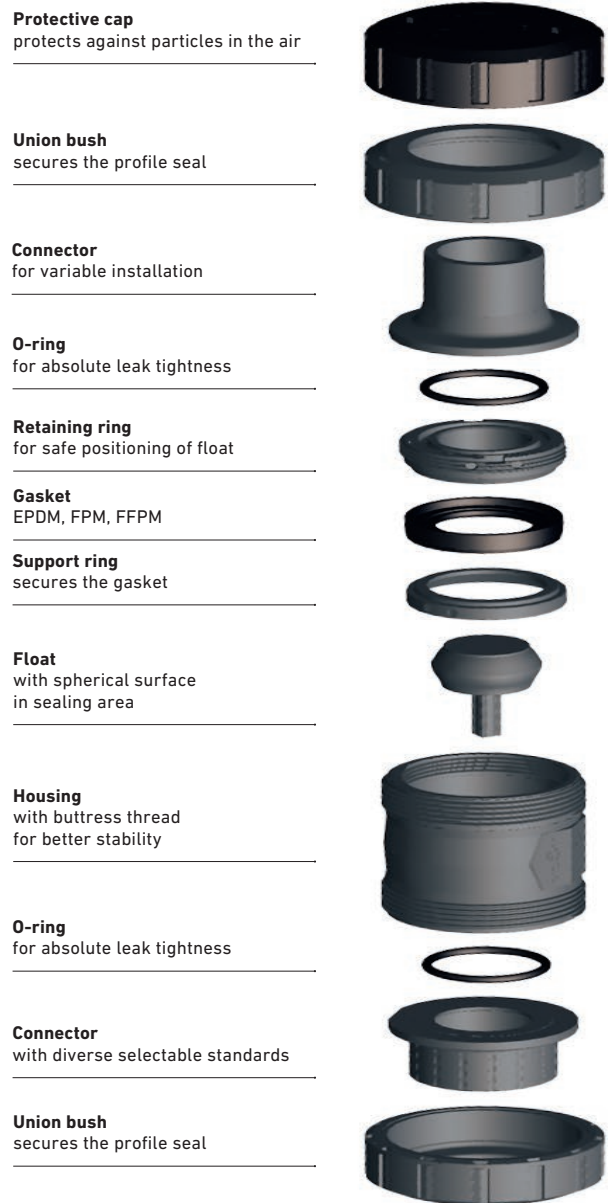

Spare parts

Elements, such as the central part, can be reordered for the ventilating and bleeding valves at any time.



Installation

Installation Tank ventilation

Venting and bleeding – pollutant-free media

If the medium in a tank is not considered a pollutant according to TA Luft regulations, a simple venting and bleed connector is sufficient.

Through an opening on the top side, the tank can be conventionally aerated and deaerated via the atmosphere. In pollutant-free applications, a ventilating and bleed valve is not absolutely necessary.

Venting and bleeding – at the highest point

Here too, the aforementioned safety characteristics and installation conditions apply. Depending on their toxicity, excess gases can be conducted directly into the atmosphere or washed in a scrubber. Other gases in the system are bled off at the highest point.





Venting and bleeding – hazardous media

If a medium is rated as a pollutant according to technical regulations for air quality (TA Luft), the vapours from the system must be discharged in a controlled manner. Gases and vapours from pressure release valves must be – provided there are no safety-related objections – conducted to the gas collection system or a waste gas purification facility. A popular method is cleaning via a scrubber or an absorption cylinder.

When filling the storage tank with compressed air, care should be taken that the compressed air does not expand suddenly in the fill line. This can damage pipes, valves and storage tanks.

In the absorption cylinder, it is important to ensure that the

water column is not higher than the permissible negative pressure in the tank. As no vapours are allowed to escape, the valve only takes over the task of ventilating. The 591 and 595 valves are ideal for this, depending on the installation. It should be ensured that the tip of the cone always points down (toward the ground); the valve must be able to open under negative pressure.

When using type 595, it has to be ensured that the opening pressure of the valve is less than the permitted negative pressure of the vessel.

Frost in winter or medium condensate can cause the cone to stick. Before starting, check that the cone sits loosely in the housing and can move freely (tapered rod). The system must be kept completely frost-free.



Calculation basis for the right valve

Dimensioning

The working pressure range should be defined so that the maximum operating pressure lies within this range, otherwise the valve will not open. The appropriate type and size of ventilating and bleed valve should be selected so that the respective air volume can be conducted off under working pressure.

Opening conditions type 595

DN (mm)	10	15	20	25	32	40	50	65	80	100
Required vacuum to lift the cone (bar)	0.028	0.028	0.030	0.030	0.035	0.040	0.050	0.060	0.060	0.060

Density of the medium

To ensure that the cone has optimal lift, the specific weights of the cone materials should be noted in relation to the density of the medium.

Cone material

Cone material	Density
PP-H	0.91 g/cm ³
ABS	1.03 g/cm ³
PP-TV (talc)	1.05 g/cm ³
PVC-U	1.38 g/cm ³
PVC-C	1.50 g/cm ³
PVDF	1.78 g/cm ³

Calculations for valve configuration

To select the correct valve size, the max. flow (Q in m³/h) is first calculated.

To do this, the flow velocity of the medium (vr) is required, as is the inner diameter of the medium-conveying pipe (di).

$$Q = V_r * \frac{\pi}{4} * d_i^2 * 0.001 * 3.6$$

The volume flow of the medium can be equated with the gas volume to be discharged or filled.

If several aerating or deaerating valves are used, each valve must be configured for the maximum flow velocity. With the calculated volume flow, the correct valve dimension can be determined from the air volume diagram. The velocity in this diagram corresponds to the discharge velocity of the gases at the valve. It is recommended that, if possible, 20m/s is not exceeded to prevent excessive wear on the valve.

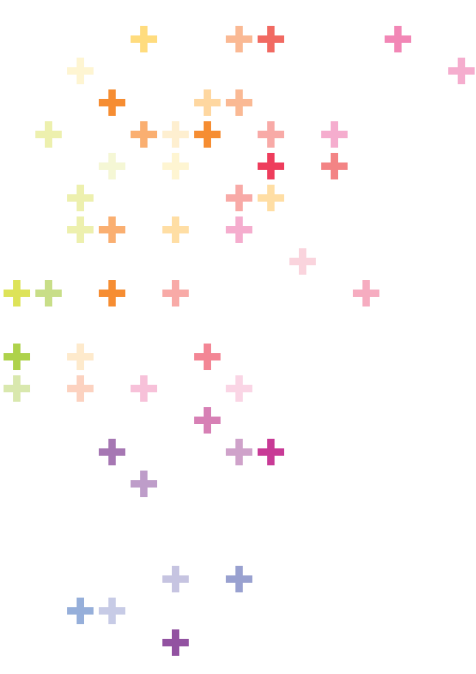

Air volume diagram

For smooth operation and a long service life, bleeders should not be overdimensioned. If the flow rate is too high for the predetermined nominal diameter of the connector, the problem can be remedied by increasing the working pressure range with correspondingly lower flow rate.

For more information, please see the Georg Fischer Planning Fundamentals, which serves as a detailed reference work in selecting a valve, or consult our website.

Air volume diagram

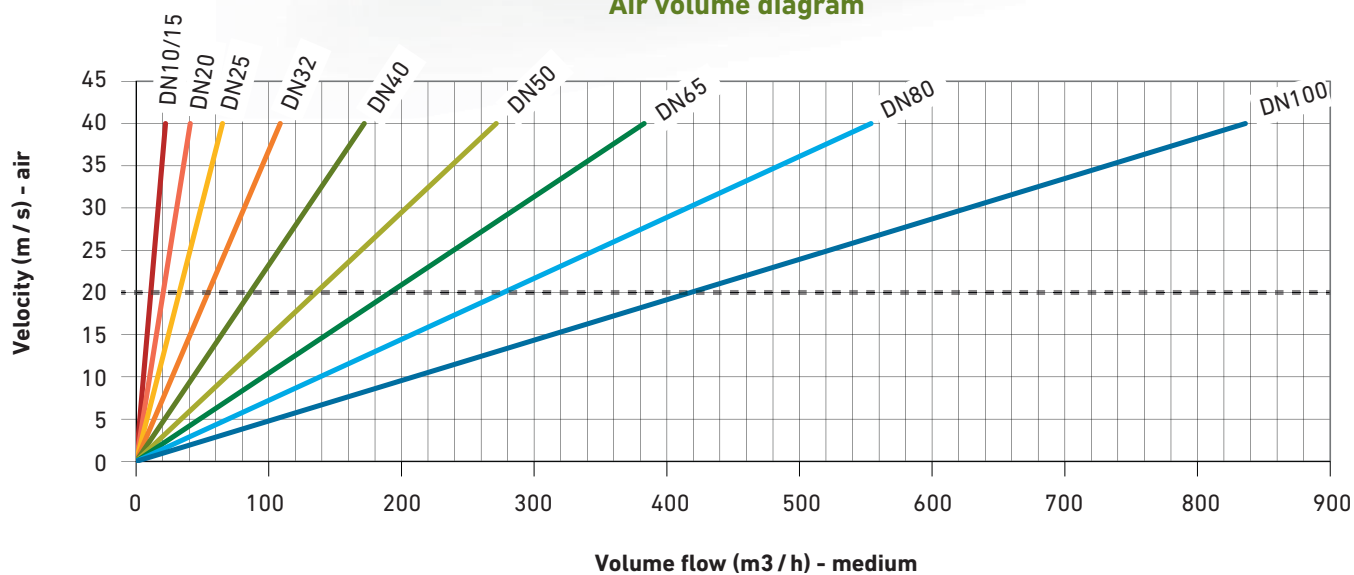

--- A speed of more than 20 m/s is not recommended. We suggest about 10 to 15 m/s as optimal speed range.

Product details

New Folder PVC-U

Ventilating and bleed valve Type 591 PVC-U With solvent cement sockets metric

Model:

- With protection cap up to DN50 made of PP-GF, DN65-100 made of POM
- Floater made of PP-H
- Designed for easy installation and removal
- Compact installation length

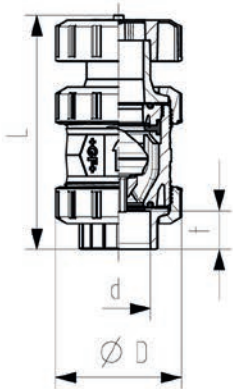

d [mm]	DN [mm]	PN [bar]	EPDM Code	FPM Code	D [mm]	L [mm]	t [mm]	closest inch [inch]
16	10	16	161 591 001	161 591 011	50	118	14	5/8
20	15	16	161 591 002	161 591 012	50	124	16	1/2
25	20	16	161 591 003	161 591 013	58	142	19	3/4
32	25	16	161 591 004	161 591 014	68	157	22	1
40	32	16	161 591 005	161 591 015	84	179	26	1 1/4
50	40	16	161 591 006	161 591 016	97	197	31	1 1/2
63	50	16	161 591 007	161 591 017	124	229	38	2
75	65	16	161 591 008	161 591 018	166	258	45	2 1/2
90	80	16	161 591 009	161 591 019	200	277	52	3
110	100	16	161 591 010	161 591 020	238	320	64	4

Ventilating and bleed valve Type 591 PVC-U With solvent cement spigots metric

Model:

- With protection cap up to DN50 made of PP-GF, DN65-100 made of POM
- Floater made of PP-H
- Designed for easy installation and removal
- Compact installation length

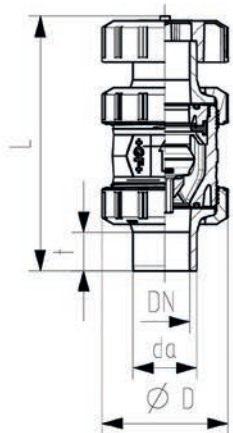

d [mm]	DN [mm]	PN [bar]	EPDM Code	FPM Code	D [mm]	L [mm]	t [mm]	closest inch [inch]
16	10	16	161 591 041	161 591 051	50	129	14	5/8
20	15	16	161 591 042	161 591 052	50	139	16	1/2
25	20	16	161 591 043	161 591 053	58	160	19	3/4
32	25	16	161 591 044	161 591 054	68	172	22	1
40	32	16	161 591 045	161 591 055	84	193	26	1 1/4
50	40	16	161 591 046	161 591 056	97	215	31	1 1/2
63	50	16	161 591 047	161 591 057	124	249	38	2
75	65	16	161 591 048	161 591 058	166	284	44	2 1/2
90	80	16	161 591 049	161 591 059	200	300	52	3
110	100	16	161 591 050	161 591 060	238	340	61	4

Product details



Ventilating and bleed valve Type 591 PVC-C With solvent cement sockets metric

Model:

- With protection cap up to DN50 made of PP-GF, DN65-100 made of POM
- Floater made of PP-H
- Designed for easy installation and removal
- Compact installation length

d [mm]	DN [mm]	PN [bar]	EPDM Code	FPM Code	D [mm]	L [mm]	t [mm]	closest inch [inch]
16	10	16	163 591 001	163 591 011	50	118	14	3/8
20	15	16	163 591 002	163 591 012	50	124	16	1/2
25	20	16	163 591 003	163 591 013	58	142	19	3/4
32	25	16	163 591 004	163 591 014	68	157	22	1
40	32	16	163 591 005	163 591 015	84	179	26	1 1/4
50	40	16	163 591 006	163 591 016	97	197	31	1 1/2
63	50	16	163 591 007	163 591 017	124	229	38	2
75	65	16	163 591 008	163 591 018	166	258	45	2 1/2
90	80	16	163 591 009	163 591 019	200	277	52	3
110	100	16	163 591 010	163 591 020	238	320	64	4

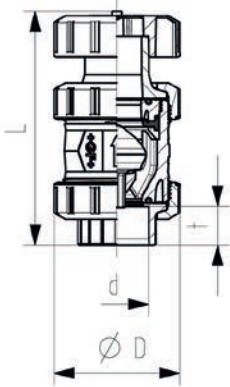

Ventilating and bleed valve Type 591 ABS With solvent cement sockets metric

Model:

- With protection cap up to DN50 made of PP-GF, DN65-100 made of POM
- Floater made of PP-H
- Designed for easy installation and removal
- Compact installation length

d [mm]	DN [mm]	PN [bar]	EPDM Code	D [mm]	L [mm]	t [mm]	closest inch [inch]
16	10	10	169 591 001	50	126	14	3/8
20	15	10	169 591 002	50	127	16	1/2
25	20	10	169 591 003	58	142	18	3/4
32	25	10	169 591 004	68	155	22	1
40	32	10	169 591 005	84	177	26	1 1/4
50	40	10	169 591 006	97	195	31	1 1/2
63	50	10	169 591 007	124	227	38	2
75	65	10	169 591 008	166	256	45	2 1/2
90	80	10	169 591 009	200	275	52	3
110	100	10	169 591 010	238	318	64	4

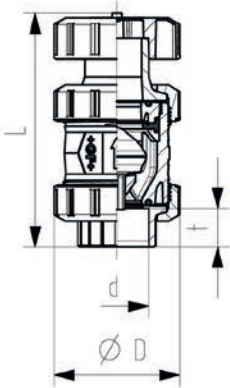

Product details



PROGEF Standard Ventilating and bleed valve type 591 With fusion sockets metric

Model:

- Material: PP-H
- With protection cap up to DN50 made of PP-GF, DN65-100 made of POM
- Floater made of PP-H
- Designed for easy installation and removal
- Compact installation length

d [mm]	DN [mm]	PN [bar]	EPDM Code	FPM Code	D [mm]	L [mm]	t [mm]	closest inch [inch]
16	10	10	167 591 001	167 591 011	50	126	14	¾
20	15	10	167 591 002	167 591 012	50	127	15	½
25	20	10	167 591 003	167 591 013	58	142	16	¾
32	25	10	167 591 004	167 591 014	68	153	18	1
40	32	10	167 591 005	167 591 015	84	171	19	1 ¼
50	40	10	167 591 006	167 591 016	97	190	21	1 ½
63	50	10	167 591 007	167 591 017	124	219	28	2
75	65	10	167 591 008	167 591 018	166	256	29	2 ½
90	80	10	167 591 009	167 591 019	200	275	33	3
110	100	10	167 591 010	167 591 020	238	318	39	4

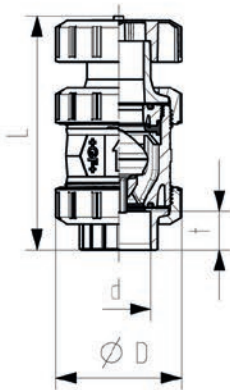

PROGEF Standard Ventilating and bleed valve type 591 With socket fusion spigots metric

Model:

- Material: PP-H
- With protection cap up to DN50 made of PP-GF, DN65-100 made of POM
- Floater made of PP-H
- Designed for easy installation and removal
- Compact installation length

d [mm]	DN [mm]	PN [bar]	EPDM Code	FPM Code	D [mm]	L [mm]	t [mm]	closest inch [inch]
16	10	10	167 591 041	167 591 051	50	135	13	¾
20	15	10	167 591 042	167 591 052	50	140	14	½
25	20	10	167 591 043	167 591 053	58	157	16	¾
32	25	10	167 591 044	167 591 054	68	168	18	1
40	32	10	167 591 045	167 591 055	84	189	20	1 ¼
50	40	10	167 591 046	167 591 056	97	211	23	1 ½
63	50	10	167 591 047	167 591 057	124	245	27	2
75	65	10	167 591 048	167 591 058	166	280	48	2 ½
90	80	10	167 591 049	167 591 059	200	296	49	3
110	100	10	167 591 050	167 591 060	238	336	54	4

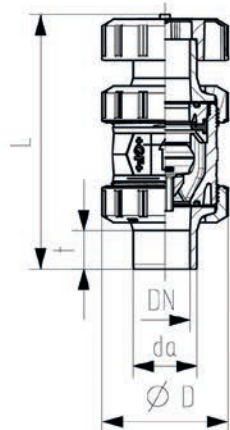

Product details



SYGEF Standard Ventilating and bleed valve type 591 With fusion sockets metric

Model:

- Material: PVDF
- With protection cap up to DN50 made of PP-GF, DN65-100 made of POM
- Special floater made of PVDF
- Designed for easy installation and removal
- Compact installation length

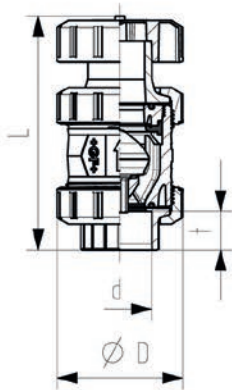

d [mm]	DN [mm]	PN [bar]	FPM Code	D [mm]	L [mm]	t [mm]	closest inch [inch]
16	10	16	175 591 011	50	126	14	3/8
20	15	16	175 591 012	50	127	15	1/2
25	20	16	175 591 013	58	142	16	3/4
32	25	16	175 591 014	68	153	18	1
40	32	16	175 591 015	84	171	19	1 1/4
50	40	16	175 591 016	97	190	21	1 1/2
63	50	16	175 591 017	124	219	26	2
75	65	16	175 591 018	166	256	33	2 1/2
90	80	16	175 591 019	200	275	37	3
110	100	16	175 591 020	238	318	43	4



SYGEF Standard Ventilating and bleed valve type 591 With socket fusion spigots metric

Model:

- Material: PVDF
- With protection cap up to DN50 made of PP-GF, DN65-100 made of POM
- Special floater made of PVDF
- Designed for easy installation and removal
- Compact installation length

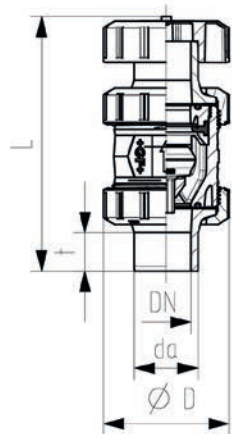

d [mm]	DN [mm]	PN [bar]	FPM Code	D [mm]	L [mm]	t [mm]	closest inch [inch]
16	10	16	175 591 031	50	135	13	3/8
20	15	16	175 591 032	50	140	14	1/2
25	20	16	175 591 033	58	157	16	3/4
32	25	16	175 591 034	68	168	18	1
40	32	16	175 591 035	84	189	20	1 1/4
50	40	16	175 591 036	97	211	23	1 1/2
63	50	16	175 591 037	124	245	27	2

Product details



Ventilating valve type 595 PVC-U With solvent cement sockets metric

Model:

- With protection cap up to DN50 made of PP-GF, DN65-100 made of POM
- Spring loaded, spring made of NIMONIC 90, HALAR coated
- Spring available in other materials, see spare parts
- Designed for easy installation and removal
- Compact installation length

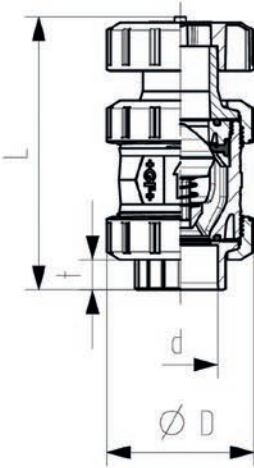

d [mm]	DN [mm]	PN [bar]	EPDM Code	FPM Code	D [mm]	L [mm]	t [mm]	closest inch [inch]
16	10	16	161 595 001	161 595 011	50	118	14	3/8
20	15	16	161 595 002	161 595 012	50	124	16	1/2
25	20	16	161 595 003	161 595 013	58	142	19	3/4
32	25	16	161 595 004	161 595 014	68	157	22	1
40	32	16	161 595 005	161 595 015	84	179	26	1 1/4
50	40	16	161 595 006	161 595 016	97	197	31	1 1/2
63	50	16	161 595 007	161 595 017	124	229	38	2
75	65	16	161 595 008	161 595 018	166	258	45	2 1/2
90	80	16	161 595 009	161 595 019	200	277	52	3
110	100	16	161 595 010	161 595 020	238	320	64	4



Ventilating valve type 595 PVC-U With solvent cement spigots metric

Model:

- With protection cap up to DN50 made of PP-GF, DN65-100 made of POM
- Spring loaded, spring made of NIMONIC 90, HALAR coated
- Spring available in other materials, see spare parts
- Designed for easy installation and removal
- Compact installation length

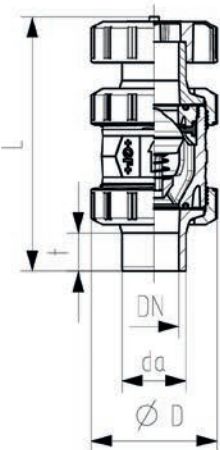

d [mm]	DN [mm]	PN [bar]	EPDM Code	FPM Code	D [mm]	L [mm]	t [mm]	closest inch [inch]
16	10	16	161 595 041	161 595 051	50	129	14	3/8
20	15	16	161 595 042	161 595 052	50	139	16	1/2
25	20	16	161 595 043	161 595 053	58	160	19	3/4
32	25	16	161 595 044	161 595 054	68	172	22	1
40	32	16	161 595 045	161 595 055	84	193	26	1 1/4
50	40	16	161 595 046	161 595 056	97	215	31	1 1/2
63	50	16	161 595 047	161 595 057	124	249	38	2
75	65	16	161 595 048	161 595 058	166	284	44	2 1/2
90	80	16	161 595 049	161 595 059	200	300	52	3
110	100	16	161 595 050	161 595 060	238	340	61	4

Product details



Ventilating valve type 595 PVC-C With solvent cement sockets metric

Model:

- With protection cap up to DN50 made of PP-GF, DN65-100 made of POM
- Spring loaded, spring made of NIMONIC 90, HALAR coated
- Spring available in other materials, see spare parts
- Designed for easy installation and removal
- Compact installation length

d [mm]	DN [mm]	PN [bar]	EPDM Code	FPM Code	D [mm]	L [mm]	t [mm]	closest inch [inch]
16	10	16	163 595 001	163 595 011	50	118	14	3/8
20	15	16	163 595 002	163 595 012	50	124	16	1/2
25	20	16	163 595 003	163 595 013	58	142	19	3/4
32	25	16	163 595 004	163 595 014	68	157	22	1
40	32	16	163 595 005	163 595 015	84	179	26	1 1/4
50	40	16	163 595 006	163 595 016	97	197	31	1 1/2
63	50	16	163 595 007	163 595 017	124	229	38	2
75	65	16	163 595 008	163 595 018	166	258	45	2 1/2
90	80	16	163 595 009	163 595 019	200	277	52	3
110	100	16	163 595 010	163 595 020	238	320	64	4

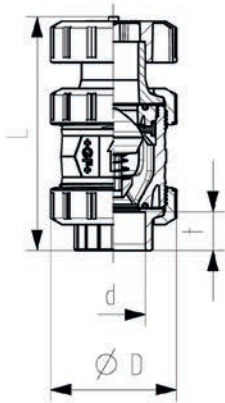

Ventilating valve type 595 ABS With solvent cement sockets metric

Model:

- Designed for easy installation and removal
- Compact installation length
- With protection cap up to DN50 made of PP-GF, DN65-100 made of POM
- Spring loaded, spring made of NIMONIC 90, HALAR coated
- Spring available in other materials, see spare parts

d [mm]	DN [mm]	PN [bar]	EPDM Code	D [mm]	L [mm]	t [mm]	closest inch [inch]
16	10	10	169 595 001	50	126	14	3/8
20	15	10	169 595 002	50	127	16	1/2
25	20	10	169 595 003	58	142	18	3/4
32	25	10	169 595 004	68	155	22	1
40	32	10	169 595 005	84	177	26	1 1/4
50	40	10	169 595 006	97	195	31	1 1/2
63	50	10	169 595 007	124	227	38	2
75	65	10	169 595 008	166	256	45	2 1/2
90	80	10	169 595 009	200	275	52	3
110	100	10	169 595 010	238	318	64	4

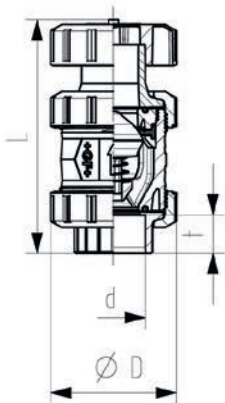
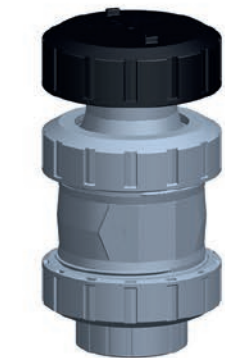

Product details



PROGEF Standard Ventilating valve type 595 With fusion sockets metric

Model:

- Material: PP-H
- With protection cap up to DN50 made of PP-GF, DN65-100 made of POM
- Spring loaded, spring made of NIMONIC 90, HALAR coated
- Spring available in other materials, see spare parts
- Designed for easy installation and removal
- Compact installation length

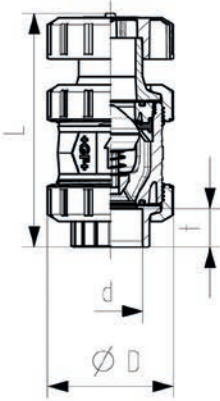

d [mm]	DN [mm]	PN [bar]	EPDM Code	FPM Code	D [mm]	L [mm]	t [mm]	closest inch [inch]
16	10	10	167 595 001	167 595 011	50	126	14	3/8
20	15	10	167 595 002	167 595 012	50	127	15	1/2
25	20	10	167 595 003	167 595 013	58	142	16	3/4
32	25	10	167 595 004	167 595 014	68	153	18	1
40	32	10	167 595 005	167 595 015	84	171	19	1 1/4
50	40	10	167 595 006	167 595 016	97	190	21	1 1/2
63	50	10	167 595 007	167 595 017	124	219	28	2
75	65	10	167 595 008	167 595 018	166	256	29	2 1/2
90	80	10	167 595 009	167 595 019	200	275	33	3
110	100	10	167 595 010	167 595 020	238	318	39	4



PROGEF Standard Ventilating valve type 595 With socket fusion spigots metric

Model:

- Material: PP-H
- With protection cap up to DN50 made of PP-GF, DN65-100 made of POM
- Spring loaded, spring made of NIMONIC 90, HALAR coated
- Spring available in other materials, see spare parts
- Designed for easy installation and removal
- Compact installation length

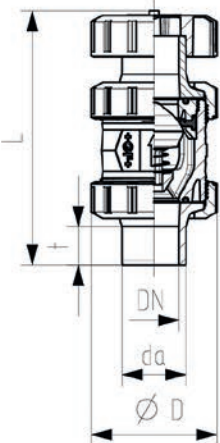

d [mm]	DN [mm]	PN [bar]	EPDM Code	FPM Code	D [mm]	L [mm]	t [mm]	closest inch [inch]
16	10	10	167 595 041	167 595 051	50	135	13	3/8
20	15	10	167 595 042	167 595 052	50	140	14	1/2
25	20	10	167 595 043	167 595 053	58	157	16	3/4
32	25	10	167 595 044	167 595 054	68	168	18	1
40	32	10	167 595 045	167 595 055	84	189	20	1 1/4
50	40	10	167 595 046	167 595 056	97	211	23	1 1/2
63	50	10	167 595 047	167 595 057	124	245	27	2
75	65	10	167 595 048	167 595 058	166	280	48	2 1/2
90	80	10	167 595 049	167 595 059	200	296	49	3
110	100	10	167 595 050	167 595 060	238	336	54	4

Product details



SYGEF Standard Ventilating valve type 595 With fusion sockets metric

Model:

- Material: PVDF
- With protection cap up to DN50 made of PP-GF, DN65-100 made of POM
- Spring loaded, spring made of NIMONIC 90, HALAR coated
- Spring available in other materials, see spare parts
- Designed for easy installation and removal
- Compact installation length

d [mm]	DN [mm]	PN [bar]	FPM Code	D [mm]	L [mm]	t [mm]	closest inch [inch]
16	10	16	175 595 011	50	126	14	3/8
20	15	16	175 595 012	50	127	15	1/2
25	20	16	175 595 013	58	142	16	3/4
32	25	16	175 595 014	68	153	18	1
40	32	16	175 595 015	84	171	19	1 1/4
50	40	16	175 595 016	97	190	21	1 1/2
63	50	16	175 595 017	124	219	26	2
75	65	16	175 595 018	166	256	33	2 1/2
90	80	16	175 595 019	200	275	37	3
110	100	16	175 595 020	238	318	43	4

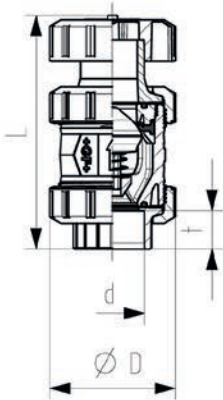

SYGEF Standard Ventilating valve type 595 With socket fusion spigots metric

Model:

- Material: PVDF
- With protection cap up to DN50 made of PP-GF, DN65-100 made of POM
- Spring loaded, spring made of NIMONIC 90, HALAR coated
- Spring available in other materials, see spare parts
- Designed for easy installation and removal
- Compact installation length

d [mm]	DN [mm]	PN [bar]	FPM Code	D [mm]	L [mm]	t [mm]	closest inch [inch]
16	10	16	175 595 031	50	135	13	3/8
20	15	16	175 595 032	50	140	14	1/2
25	20	16	175 595 033	58	157	16	3/4
32	25	16	175 595 034	68	168	18	1
40	32	16	175 595 035	84	189	20	1 1/4
50	40	16	175 595 036	97	211	23	1 1/2
63	50	16	175 595 037	124	245	27	2

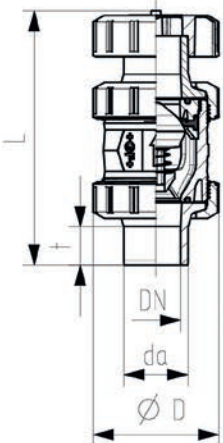

Product details

Spare parts ventilating- and bleed valve type 591/595

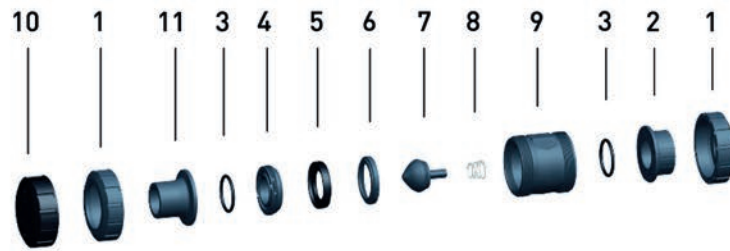

Central part with spring

Model:

- Central body consisting of: housing (9), union bush (4), support ring (6), floater (7), spring Nimonic 90 Halar coated (8), profile seal ring (5) and face seal (3)

d [mm]	DN [mm]	Size [inch]	PVC-U EPDM Code	Weight [kg]	PVC-U FPM Code	Weight [kg]	PVC-C EPDM Code	Weight [kg]
16	10	3/8	161 485 281	0.070	161 485 291	0.070	163 485 281	0.070
20	15	1/2	161 485 281	0.070	161 485 291	0.070	163 485 281	0.070
25	20	3/4	161 485 282	0.170	161 485 292	0.190	163 485 282	0.190
32	25	1	161 485 283	0.160	161 485 293	0.160	163 485 283	0.170
40	32	1 1/4	161 485 284	0.270	161 485 294	0.270	163 485 284	0.290
50	40	1 1/2	161 485 285	0.400	161 485 295	0.400	163 485 285	0.440
63	50	2	161 485 286	0.710	161 485 296	0.720	163 485 286	0.780
75	65	2 1/2	161 485 287	1.580	161 485 297	1.590	163 485 287	1.730
90	80	3	161 485 288	2.520	161 485 298	2.550	163 485 288	2.760
110	100	4	161 485 289	4.140	161 485 299	4.180	163 485 289	4.530

d [mm]	PVC-C FPM Code	Weight [kg]	ABS EPDM Code	Weight [kg]	PP-H EPDM Code	Weight [kg]
16	163 485 291	0.070	169 485 281	0.050	167 485 281	0.040
20	163 485 291	0.070	169 485 281	0.050	167 485 281	0.040
25	163 485 292	0.210	169 485 282	0.140	167 485 282	0.100
32	163 485 293	0.170	169 485 283	0.130	167 485 283	0.090
40	163 485 294	0.290	169 485 284	0.220	167 485 284	0.150
50	163 485 295	0.440	169 485 285	0.330	167 485 285	0.220
63	163 485 296	0.780	169 485 286	0.590	167 485 286	0.390
75	163 485 297	1.740	169 485 287	1.310	167 485 287	0.880
90	163 485 298	2.790	169 485 288	2.100	167 485 288	1.400
110	163 485 299	4.580	169 485 289	3.450	167 485 289	2.300

d [mm]	PP-H FPM Code	Weight [kg]	PVDF FPM Code	Weight [kg]
16	167 485 291	0.040	175 485 291	0.050
20	167 485 291	0.040	175 485 291	0.050
25	167 485 292	0.090	175 485 292	0.130
32	167 485 293	0.090	175 485 293	0.110
40	167 485 294	0.150	175 485 294	0.190
50	167 485 295	0.220	175 485 295	0.280
63	167 485 296	0.390	175 485 296	0.510
75	167 485 297	0.870	175 485 297	1.130
90	167 485 298	1.390	175 485 298	1.800
110	167 485 299	2.270	175 485 299	2.960

Product details



Central part without spring

Model:

- Central body consisting of: housing (9), union bush (4), support ring (6), floater PP-H/ PVDF (7), profile seal ring (5) and face seal (3)

d [mm]	DN [mm]	Size [inch]	PVC-U EPDM Code	Weight [kg]	PVC-U FPM Code	Weight [kg]	PVC-C EPDM Code	Weight [kg]
16	10	3/8	161 485 261	0.070	161 485 271	0.070	163 485 261	0.070
20	15	1/2	161 485 261	0.070	161 485 271	0.070	163 485 261	0.070
25	20	3/4	161 485 262	0.170	161 485 272	0.190	163 485 262	0.190
32	25	1	161 485 263	0.160	161 485 273	0.160	163 485 263	0.170
40	32	1 1/4	161 485 264	0.270	161 485 274	0.270	163 485 264	0.290
50	40	1 1/2	161 485 265	0.400	161 485 275	0.400	163 485 265	0.440
63	50	2	161 485 266	0.710	161 485 276	0.720	163 485 266	0.780
75	65	2 1/2	161 485 267	1.580	161 485 277	1.590	163 485 267	1.730
90	80	3	161 485 268	2.520	161 485 278	2.550	163 485 268	2.760
110	100	4	161 485 269	4.140	161 485 279	4.180	163 485 269	4.530

d [mm]	PVC-C FPM Code	Weight [kg]	ABS EPDM Code	Weight [kg]	PP-H EPDM Code	Weight [kg]
16	163 485 271	0.070	169 485 261	0.050	167 485 261	0.040
20	163 485 271	0.070	169 485 261	0.050	167 485 261	0.040
25	163 485 272	0.210	169 485 262	0.130	167 485 262	0.110
32	163 485 273	0.170	169 485 263	0.120	167 485 263	0.100
40	163 485 274	0.290	169 485 264	0.200	167 485 264	0.180
50	163 485 275	0.440	169 485 265	0.300	167 485 265	0.260
63	163 485 276	0.780	169 485 266	0.540	167 485 266	0.470
75	163 485 277	1.740	169 485 267	1.200	167 485 267	1.040
90	163 485 278	2.790	169 485 268	1.920	167 485 268	1.660
110	163 485 279	4.580	169 485 269	3.150	167 485 269	2.730

d [mm]	PP-H FPM Code	Weight [kg]	PVDF FPM Code	Weight [kg]
16	167 485 271	0.040	175 485 271	0.080
20	167 485 271	0.040	175 485 271	0.080
25	167 485 272	0.120	175 485 272	0.240
32	167 485 273	0.100	175 485 273	0.200
40	167 485 274	0.180	175 485 274	0.350
50	167 485 275	0.260	175 485 275	0.520
63	167 485 276	0.470	175 485 276	0.920
75	167 485 277	1.050	175 485 277	2.060
90	167 485 278	1.680	175 485 278	3.290
110	167 485 279	2.760	175 485 279	5.390

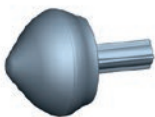

Cone (7)

d [mm]	Size [inch]	DN [mm]	PVC-U Code	PVC-C Code	ABS Code	PP-H Code	PP-Talkum 20% Code	PVDF Code
16	3/8	10	161 491 151	163 482 151	169 482 151	167 485 151	167 485 351	175 484 151
20	1/2	15	161 491 151	163 482 151	169 482 151	167 485 151	167 485 351	175 484 151
25	3/4	20	161 491 152	163 482 152	169 482 152	167 485 152	167 485 352	175 484 152
32	1	25	161 491 153	163 482 153	169 482 153	167 485 153	167 485 353	175 484 153
40	1 1/4	32	161 491 154	163 482 154	169 482 154	167 485 154	167 485 354	175 484 154
50	1 1/2	40	161 491 155	163 482 155	169 482 155	167 485 155	167 485 355	175 484 155
63	2	50	161 491 156	163 482 156	169 482 156	167 485 156	167 485 356	175 484 156
75	2 1/2	65	161 491 157	163 482 157	169 482 157	167 485 157	167 485 357	175 484 157
90	3	80	161 491 158	163 482 158	169 482 158	167 485 158	167 485 358	175 484 158
110	4	100	161 491 159	163 482 159	169 482 159	167 485 159	167 485 359	175 484 159

Product details



Floater (7)

Model:

- For type 591

d [mm]	DN [mm]	Size [inch]	PP-H Code	Weight [kg]	PVDF Code	Weight [kg]
16	10	3/8	167 485 151	0.003	175 484 161	0.005
20	15	1/2	167 485 151	0.003	175 484 161	0.005
25	20	3/4	167 485 152	0.006	175 484 162	0.008
32	25	1	167 485 153	0.012	175 484 163	0.016
40	32	1 1/4	167 485 154	0.024	175 484 164	0.017
50	40	1 1/2	167 485 155	0.044	175 484 165	0.024
63	50	2	167 485 156	0.069	175 484 166	0.039
75	65	2 1/2	167 485 157	0.152	175 484 167	0.098
90	80	3	167 485 158	0.265	175 484 168	0.162
110	100	4	167 485 159	0.485	175 484 169	0.325



Protective cap (10)

Model:

- Protects the piping system from dirt particles out of the ambient air. Can also be used as tool for opening and closing the valve union bushing.

d [mm]	DN [mm]	Size [inch]	PP-GF Code	Weight [kg]
16	10	3/8	167 485 361	0.017
20	15	1/2	167 485 361	0.017
25	20	3/4	167 485 362	0.023
32	25	1	167 485 363	0.034
40	32	1 1/4	167 485 364	0.052
50	40	1 1/2	167 485 365	0.069
63	50	2	167 485 366	0.103



Seal set

Model:

- Seal set consisting of: profile seal ring (5) and face seal (3)

d [mm]	DN [mm]	Size [inch]	EPDM Code	Weight [kg]	FPM Code	Weight [kg]
16	10	3/8	161 485 241	0.010	161 485 251	0.009
20	15	1/2	161 485 241	0.010	161 485 251	0.009
25	20	3/4	161 485 242	0.007	161 485 252	0.010
32	25	1	161 485 243	0.010	161 485 253	0.015
40	32	1 1/4	161 485 244	0.130	161 485 254	0.020
50	40	1 1/2	161 485 245	0.220	161 485 255	0.039
63	50	2	161 485 246	0.047	161 485 256	0.052
75	65	2 1/2	161 485 247	0.074	161 485 257	0.128
90	80	3	161 485 248	0.111	161 485 258	0.184
110	100	4	161 485 249	0.188	161 485 259	0.318



Spring (8)

Model:

- Material: V2A, code: 1.4310, HALAR® coated

d [mm]	DN [mm]	Size [inch]	V2A, HALAR coated Code	Weight [kg]
16	10	3/8	161 485 112	0.001
20	15	1/2	161 485 112	0.001
25	20	3/4	161 485 112	0.001
32	25	1	161 485 113	0.001
40	32	1 1/4	161 485 114	0.002
50	40	1 1/2	161 485 115	0.002

Product details

d [mm]	DN [mm]	Size [inch]	V2A, HALAR coated Code	Weight [kg]	
63	50	2	161 485 116	0.003	
75	65	2 ½	161 485 117	0.003	
90	80	3	161 485 118	0.004	
110	100	4	161 485 119	0.004	



DN10/15 - 50



Handle for dismantling

d [mm]	DN [mm]	Size [inch]	red Code	Weight [kg]	black Code	Weight [kg]	
16	10	¾	167 484 088	0.012	167 484 076	0.012	
20	15	½	167 484 088	0.012	167 484 076	0.012	
25	20	¾	167 484 089	0.022	167 484 077	0.022	
32	25	1	167 484 090	0.022	167 484 078	0.022	
40	32	1 ¼	167 484 091	0.042	167 484 079	0.042	
50	40	1 ½	167 484 092	0.042	167 484 080	0.042	
63	50	2	167 484 093	0.064	167 484 081	0.059	
75	65	2 ½	167 484 094	0.250	167 484 082	0.250	
90	80	3	167 484 095	0.250	167 484 083	0.250	
110	100	4	167 484 096	0.298	167 484 084	0.298	

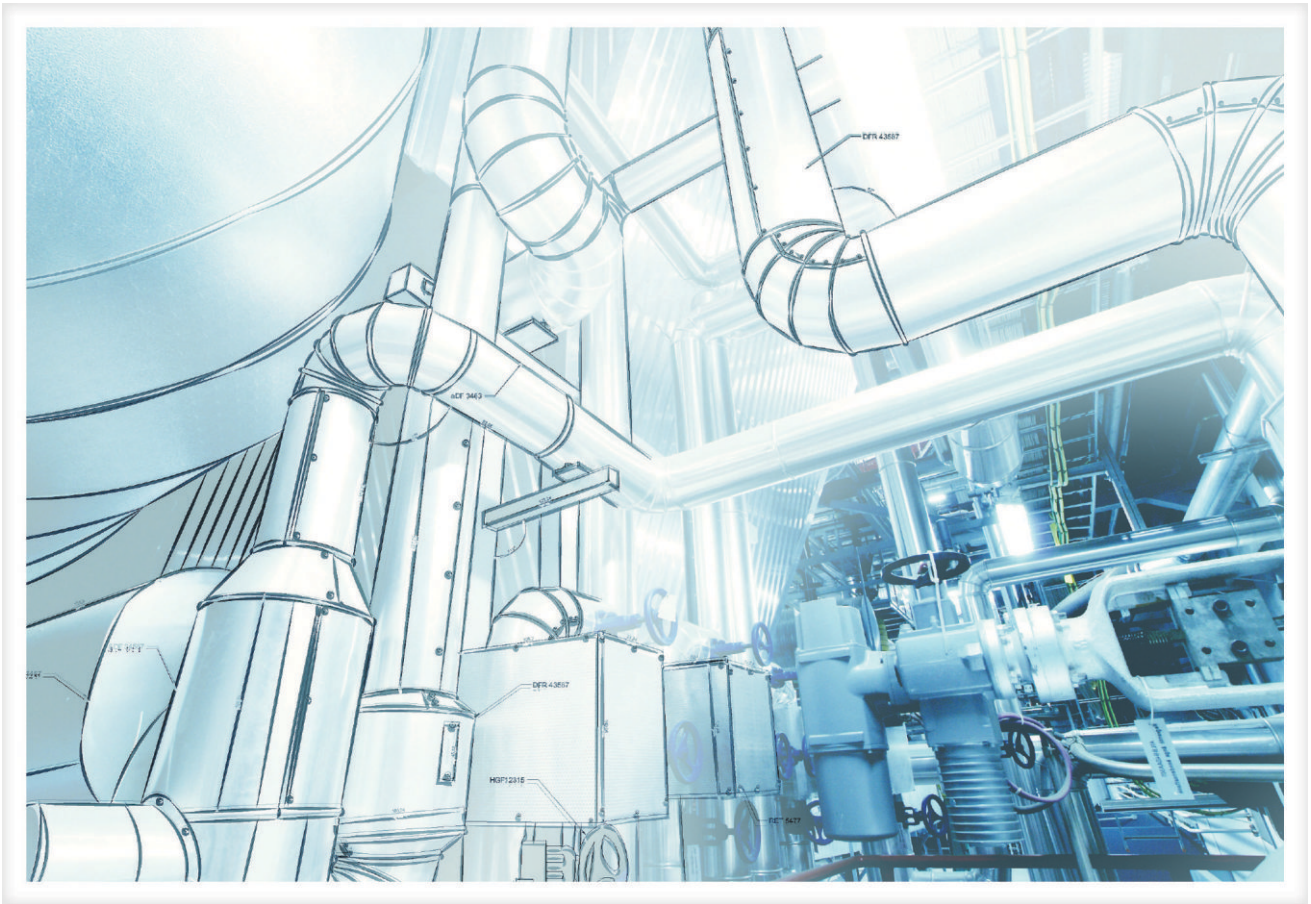

GF Africa **Contact Details**

T. + 27 21 702 0059

E. info@gf-africa.com

W. www.gf-africa.com

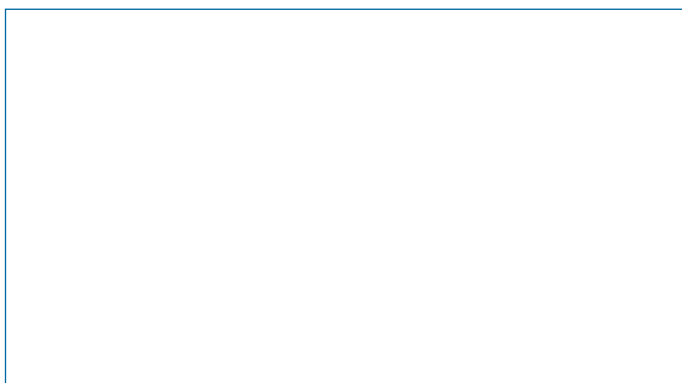

Authorised Distributor

