

# Throttle Valve Type V251



## Product description

Throttle valves are used wherever fluids or gases need to be throttled in pipelines. The compact design, simple and robust construction and good control characteristics ensure high operational safety.

### Function

A spindle with cone narrows the cross-section of the opening in the housing, thus restricting the volume flow to the desired value. The setting must be made using a tool (screwdriver or flat material), which has the advantage that the set value cannot be changed unintentionally.

### Applications

- Chemical dosing
- Water treatment

### Benefits/features

- Good chemical resistance thanks to highly resistant plastics (PVC, PP, PVDF)
- Requires practically no maintenance and can be installed in any position
- High operational safety thanks to compact and robust construction
- Good control characteristics

### Flow media

Neutral and aggressive media with a small quantity of particles/solids. The chemical resistance depends on the selected valve material ([see online tool ChemRes PLUS](#)).

# Technical data

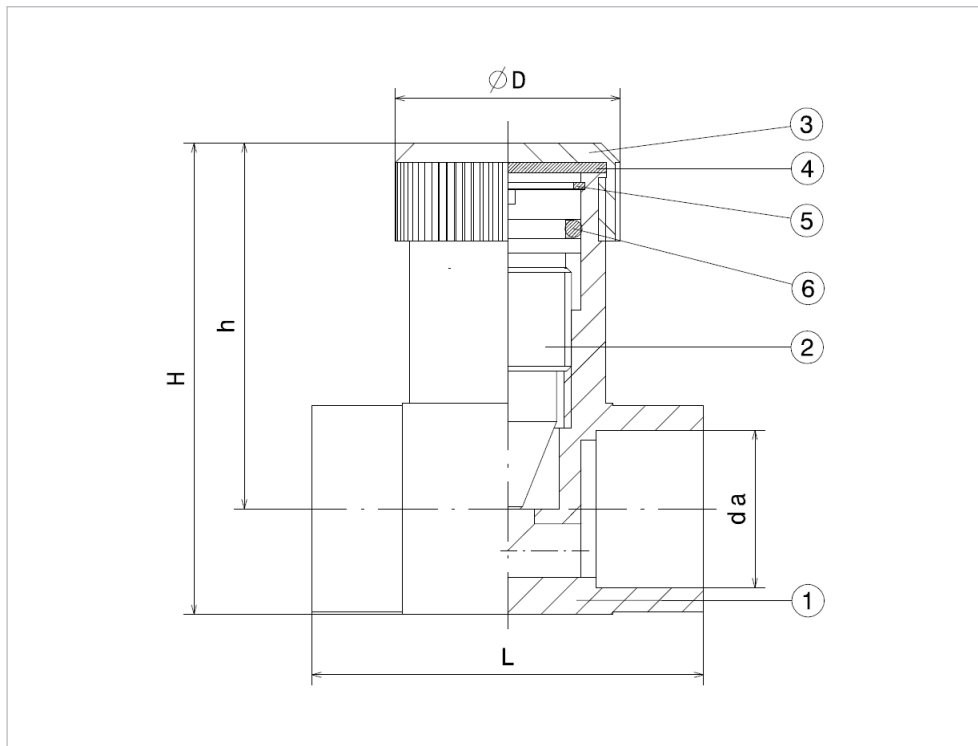

- ① Housing
- ② Spindle
- ③ Cap
- ④ Gasket
- ⑤ Stop ring
- ⑥ O-ring

Specification	
Dimensions	d16/DN10 – d63/DN50
Materials	PVC-U PP PVDF
Gasket materials	EPDM/FKM (PVDF: FKM)
Pressure level	PN10
Setting range	100 - 20 000 l/h
Connections	Cement and fusion spigot
Assembly	Unrestricted
Standards	ISO (metric)

## Dimensions

d (mm)	DN (mm)	L (mm)	H (mm)	h (mm)	D (mm)
16	10	47	57	45	29
20	15	55	66	51	35
25	20	66	80	62.5	40
32	25	80	96	74.5	47
40	32	100	111	86	56
50	40	120	133	101	70
63	50	146	158	118	88

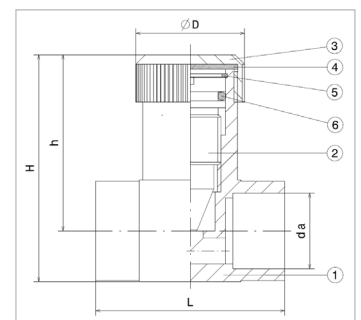

Flow characteristics

X Open angle (%)  
 Y Kv, Cv value (%)

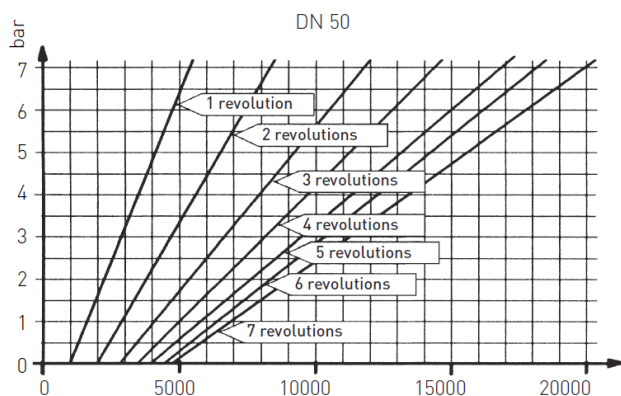
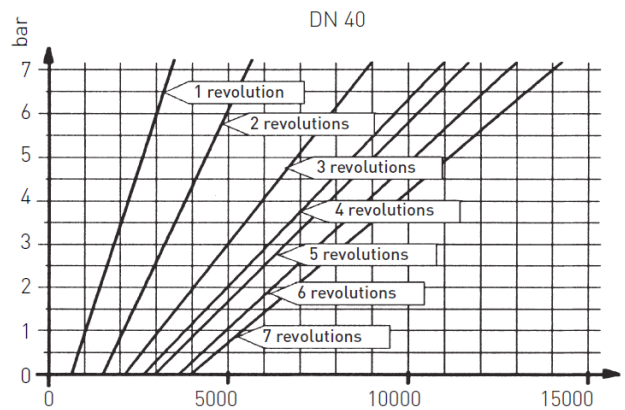
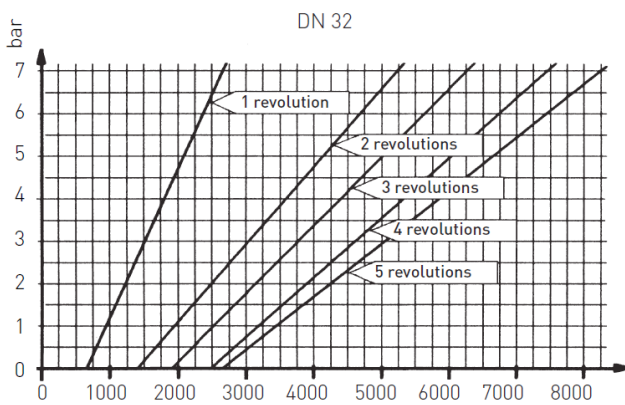
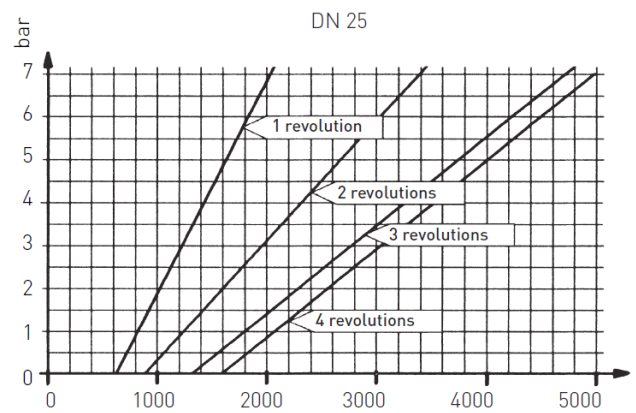
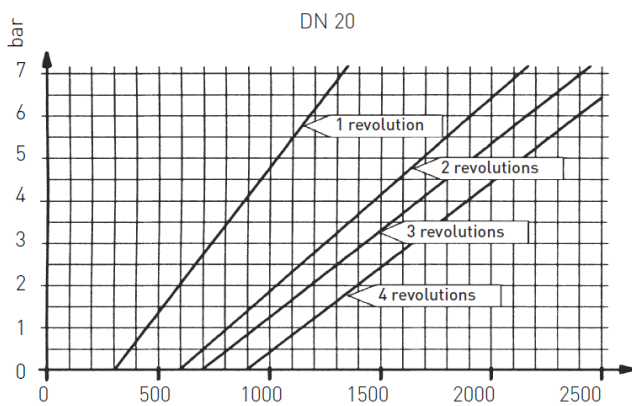
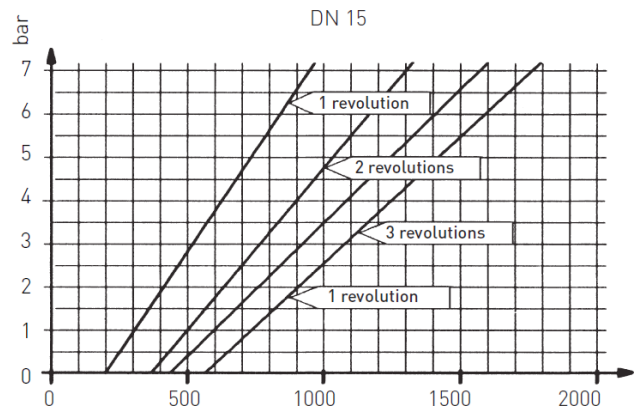
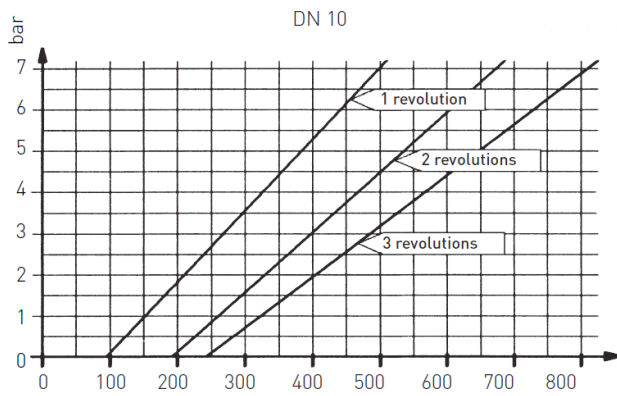

**Example**

Pressure upstream: 3 bar

Desired flow: 2,000 l/h

- Diagram for DN25, with the set screw opened 2 revolutions and a flow of 2,000 l/h.
- The nominal diameter DN25 is well suited for this purpose.

The information and technical data (altogether "Data") herein are not binding, unless explicitly confirmed in writing. The Data neither constitutes any expressed, implied or warranted characteristics, nor guaranteed properties or a guaranteed durability. All Data is subject to modification. The General Terms and Conditions of Sale of Georg Fischer Piping Systems apply.

09/2020-A

© Georg Fischer Piping Systems Ltd, 8201 Schaffhausen/Switzerland

# Water Jet Suction Pump Type P20



## 1 Product description

The P20 water jet suction pump can be used in cases where liquid that is under pressure is present as a propellant. They are used for transporting and mixing liquids. They are self-priming and have no mechanically moving parts.

### Function

The basic principle of the water jet suction pump is that the propellant liquid passes through a nozzle and draws in with it the liquid or gaseous medium from the suction line, increasing its velocity. The result of this is that the propellant and the medium that is sucked in are mixed together. The amount of liquid propelled is a function of the propellant pressure and the size of the nozzle. The amount of medium drawn in can be seen from the diagrams. The results shown are only guidelines and depend on the method of operation.

### Applications

- Aquariums
- Chemical process industry
- Industrial water treatment
- Swimming pools

### Benefits/features

- No external energy required for operation
- Ideal for mixing, dosing and transporting liquids
- No mechanically moving parts
- Self-priming

### Flow media

Neutral and aggressive media free of particles/solids. The chemical resistance depends on the selected material (see list of chemical resistance from GF Piping Systems).

## 2 Technical basics

### 2.1 Principle of functionality

The propellant (liquid) flows through a nozzle. Due to this, a negative pressure (vacuum) is created. The liquid or gas suction medium is sucked out through an increase in speed.

The propellant and the suction medium are ideally mixed. The amount of liquid propelled is a function of the propellant pressure and the size of the nozzle. The amount of liquid drawn in can be seen from the diagrams. The results shown are only guidelines and depend on the method of operation.

A throttle is connected to the suction pipe to enable optimal dosing.

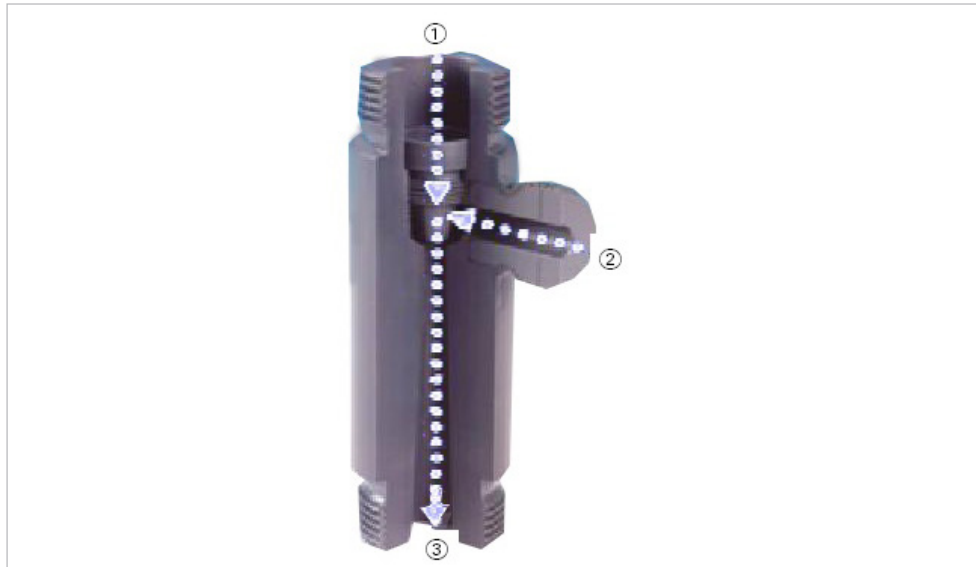

- ① Propellant
- ② Suction medium (suction pipe)
- ③ Mixture of propellant and suction medium (outlet)

### 2.2 Valve handling

#### Installation notes

- We recommend installing the water jet pump between two detachable pipe sections. With a view to subsequent dismantling, it is useful to provide shut-off devices.
- Relaxation zones of at least 5 x DN are to be provided upstream and downstream of the pump.
- It is recommended to install a flow meter in the suction pipe to provide information on the suction power of the pump.
- It is useful to install manometers upstream and downstream of the jet pump for reading the inlet pressure and the back pressure.
- The suction time can be significantly reduced by installing a check valve in the suction pipe.
- Inlet and outlet pipes must have at least the nominal diameter of the pump.
- An exact dosing of the propellant and suction flow is guaranteed through the installation of throttle valves.



**Installation and maintenance must be performed in accordance with the corresponding installation manual. The installation manual is provided with the product, see also the online product catalogue at [www.gfps.com](http://www.gfps.com).**

### 3 Technical data

#### 3.1 Specifications

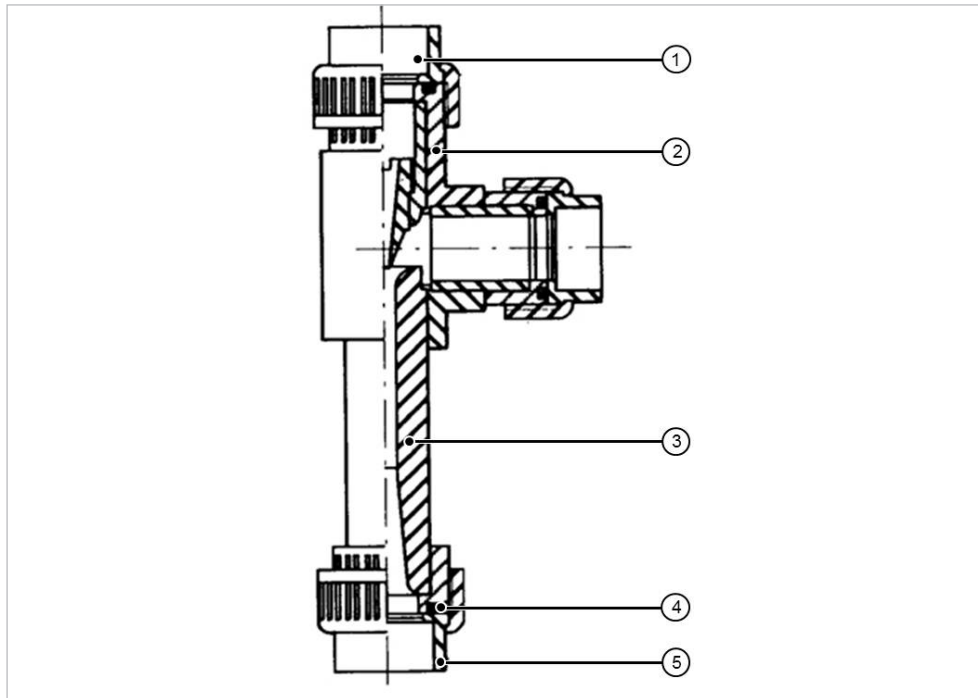

- ① Coupling nut
- ② Nozzle
- ③ Water jet suction pump
- ④ O-ring
- ⑤ Insert

Specification	
Dimensions	d16/DN10 – d90/DN80, 3/8" – 3"
Materials	PVC-U, PP-H, PVDF
Gasket materials	EPDM, FKM
Connections	DN10 – DN20                      Threads DIN/ISO
	DN20 – DN50                      Screws DIN/ISO
	DN65 – DN80                      Cement spigots DIN/ISO
Nominal pressure	PN10

#### 3.2 Pressure-temperature diagrams

The following pressure-temperature diagrams are based on a lifetime of 25 years and water or similar media.

PVC-U, PP-H, PVDF

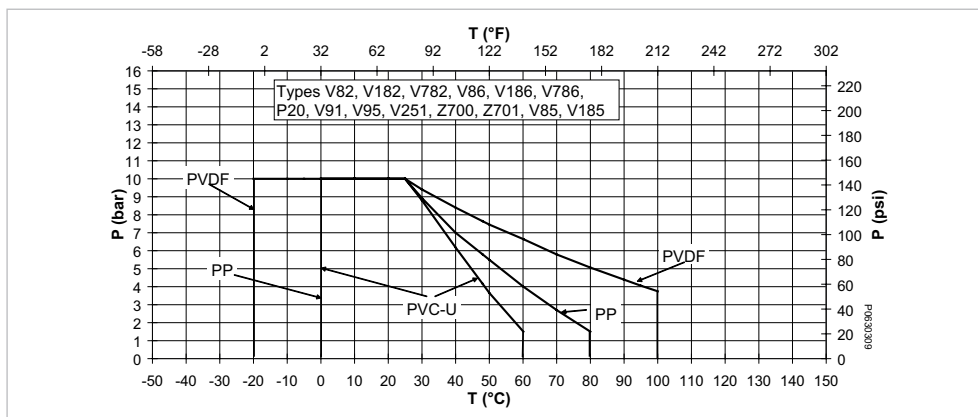

T Temperature (°C, °F)  
 P Permissible pressure (bar, psi)

### 3.3 Dimensions

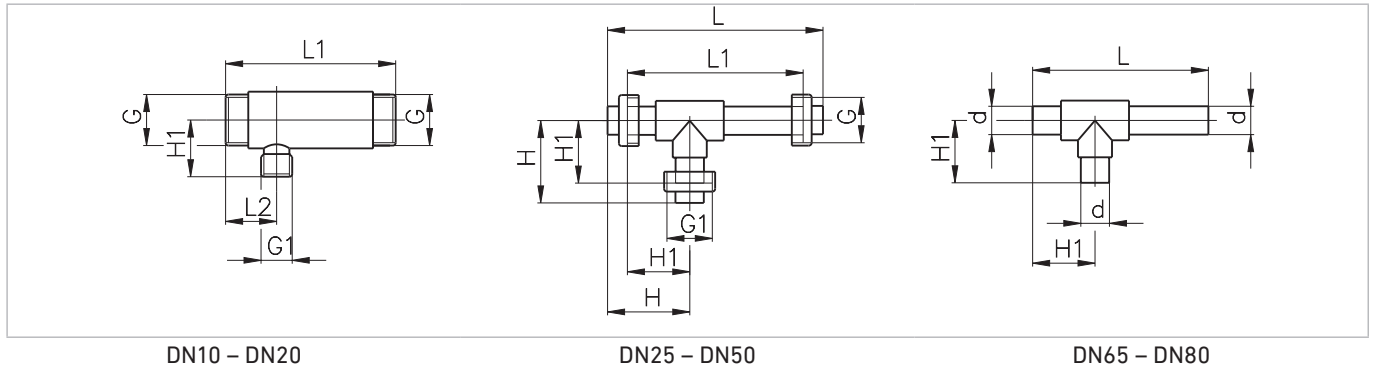

	da (mm)	DN (mm)	G	G1	L (mm)	L1 (mm)	t (mm)	H (mm)	h (mm)
P 20.10 - 1.5	16	10	R ¾"	R ¾"	-	110	40	-	35
P 20.10 - 2.0									
P 20.15 - 2.0	20	15	R 1"	R ¾"	-	125	40	-	35
P 20.15 - 3.0									
P 20.15 - 4.0									
P 20.20 - 3.0	25	20	R ¼"	R ¾"	-	145	45	-	45
P 20.20 - 4.5									
P 20.20 - 6.0									
P 20.25 - 2.5	32	25	R 1½"	R 1½"	245	195	-	96	71
P 20.25 - 4.0									
P 20.25 - 5.0									
P 20.32 - 3.0	40	32	R 2"	R 2"	297	239	-	116	87
P 20.32 - 4.5									
P 20.32 - 6.0									
P 20.40 - 3.5	50	40	R 2 ¼"	R 2 ¼"	369	301	-	139	105
P 20.40 - 5.5									
P 20.40 - 7.5									
P 20.50 - 5.0	63	50	R 2 ¾"	R 2 ¾"	433	351	-	169	128
P 20.50 - 7.0									
P 20.50 - 9.0									
P 20.65 - 6.5	75	65	-	-	388	-	-	-	115
P 20.65 - 9.0									
P 20.65 - 11.5									
P 20.80 - 8.0	90	80	-	-	465	-	-	-	149
P 20.80 - 11.0									
P 20.80 - 14.0									



### 3.4 Characteristic curves

Suction medium: water

Suction medium: air

DN10, nozzle size 1.5

DN10, nozzle size 1.5

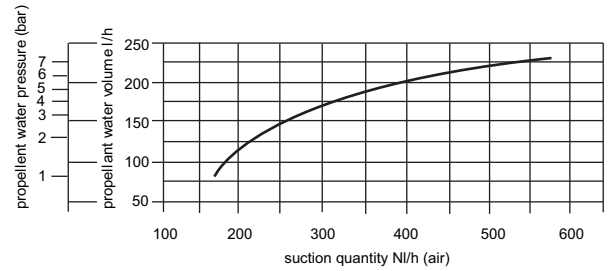
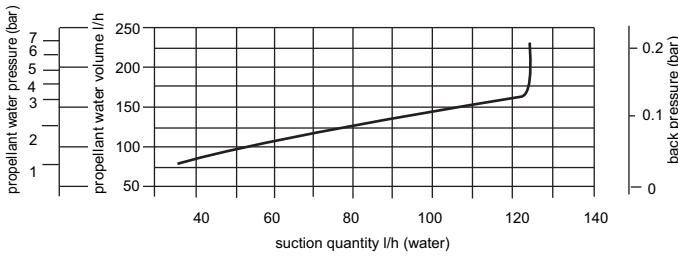

DN10, nozzle size 2.5

DN10, nozzle size 2.5

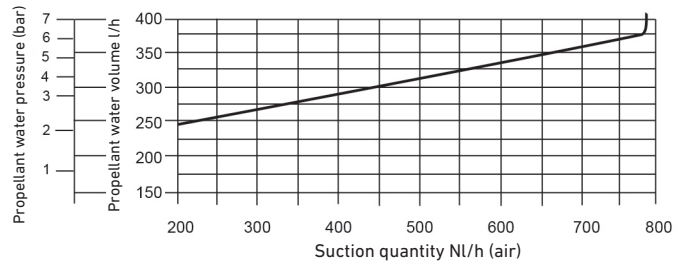
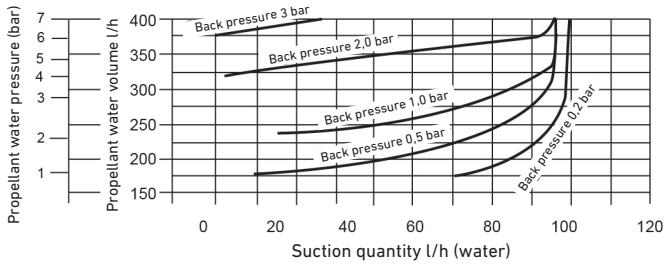

DN15, nozzle size 2.0

DN15, nozzle size 2.0

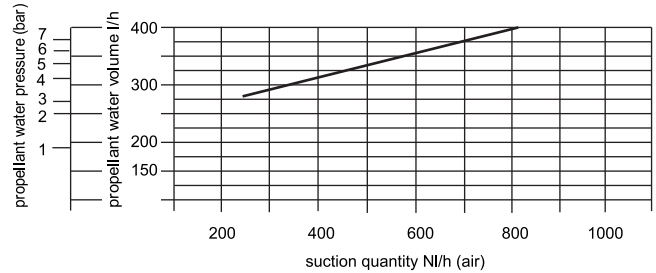
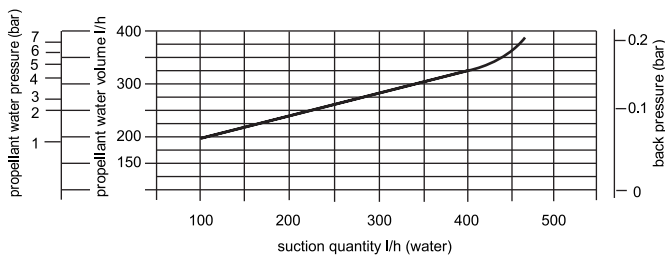

DN15, nozzle size 3.0

DN15, nozzle size 3.0

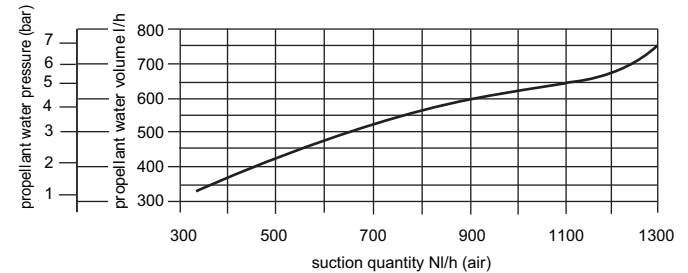
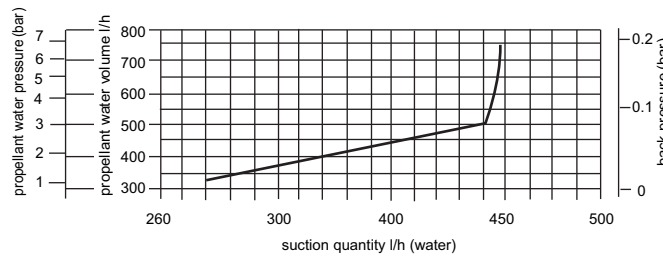

DN15, nozzle size 4.0

DN15, nozzle size 4.0

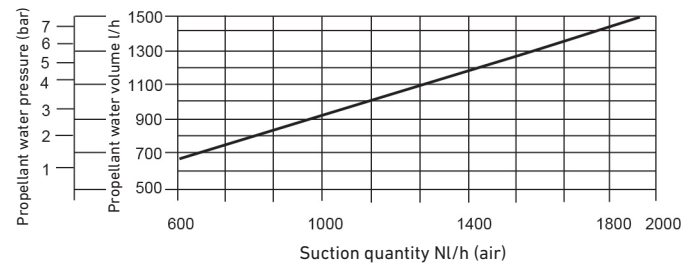
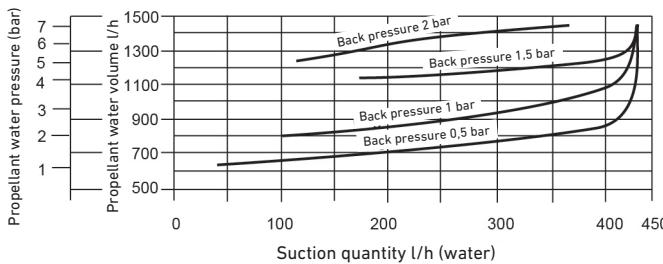

# Water Jet Suction Pump Type P20

Suction medium: water

Suction medium: air

DN20, nozzle size 3.0

DN20, nozzle size 3.0

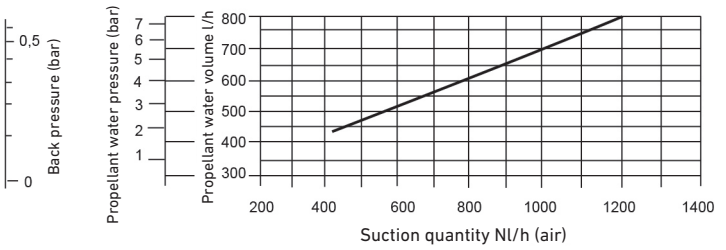
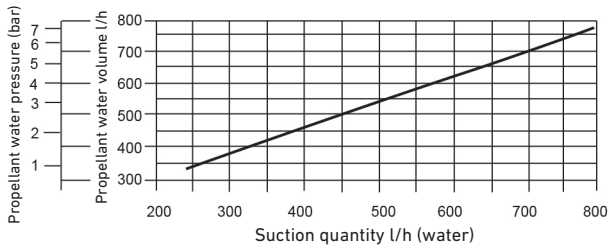

DN20, nozzle size 4.5

DN20, nozzle size 4.5

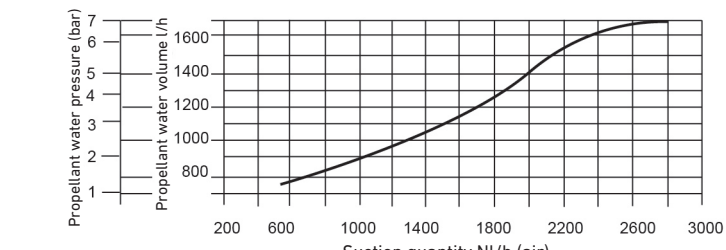
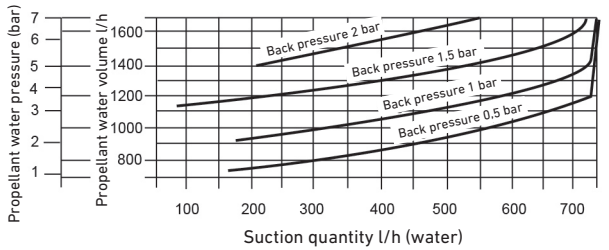

DN20, nozzle size 6.0

DN20, nozzle size 6.0

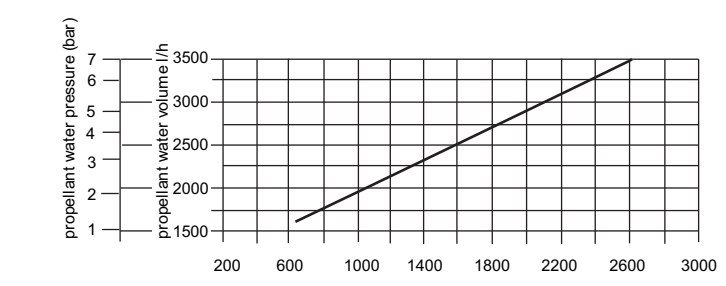
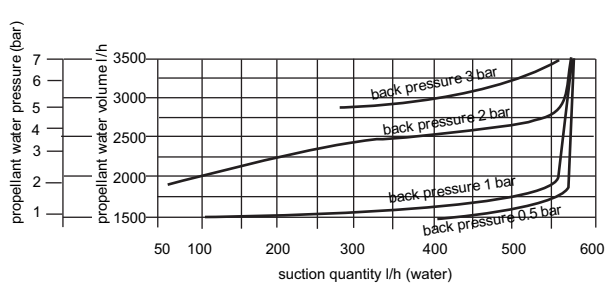

DN25, nozzle size 2.5

DN25, nozzle size 2.5

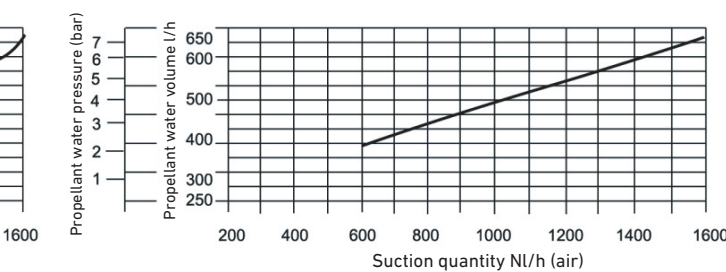
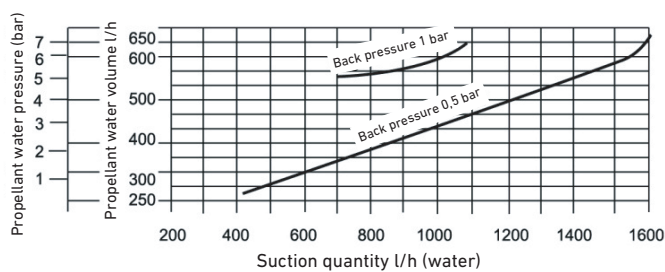

DN25, nozzle size 4.0

DN25, nozzle size 4.0

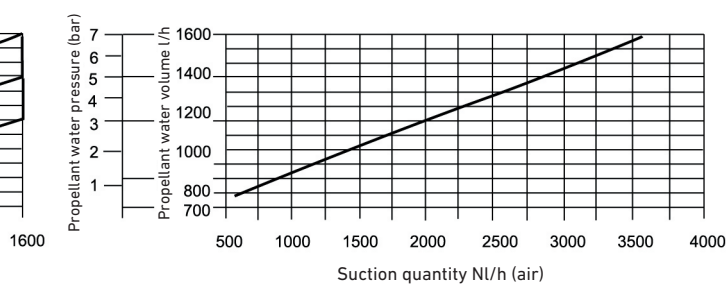
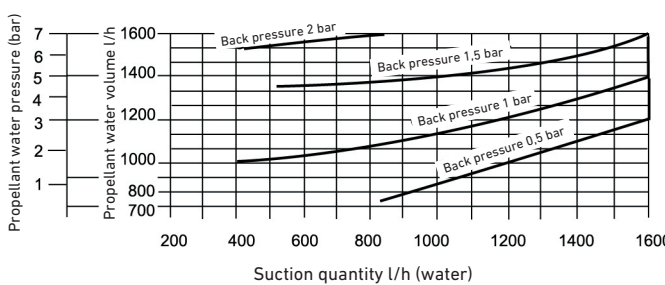

Suction medium: water

Suction medium: air

DN25, nozzle size 5.0

DN25, nozzle size 5.0

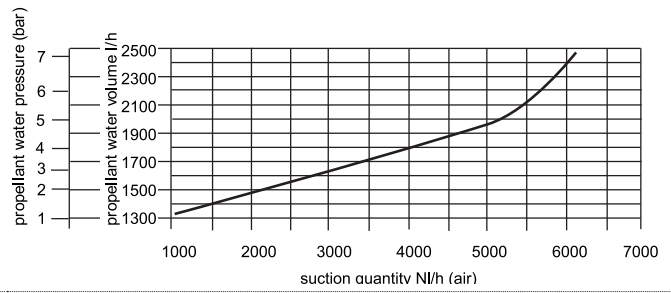
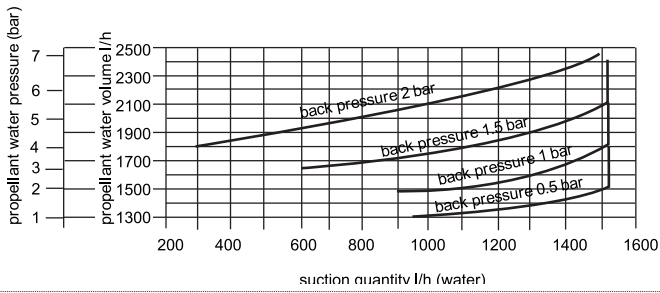

DN32, nozzle size 3.0

DN32, nozzle size 3.0

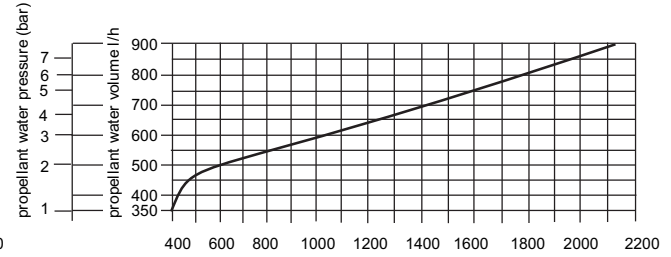
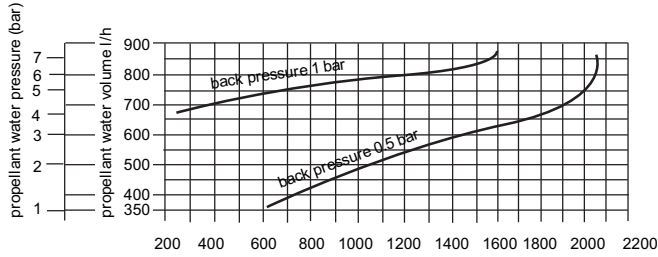

DN32, nozzle size 4.5

DN32, nozzle size 4.5

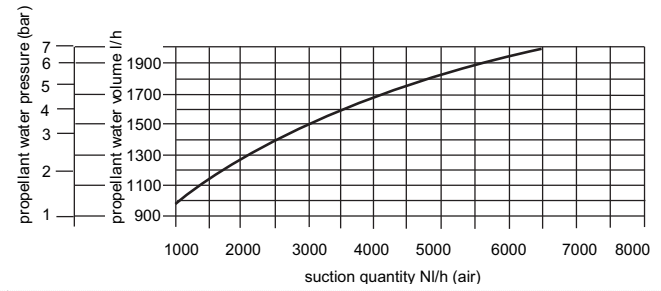
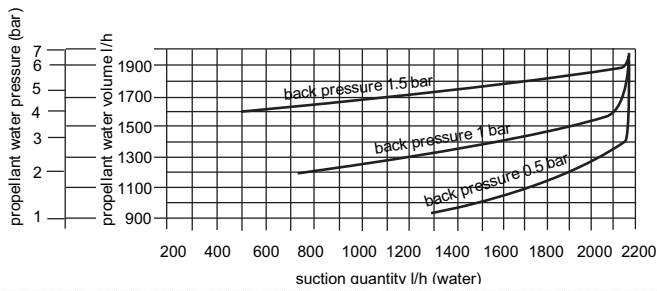

DN32, nozzle size 6.0

DN32, nozzle size 6.0

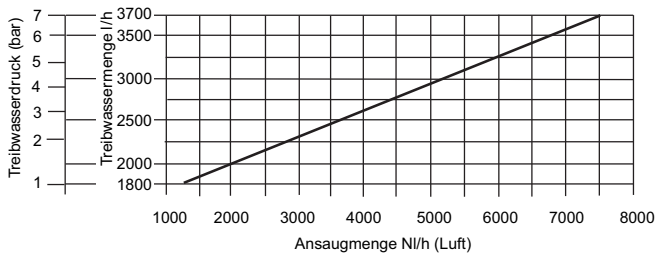
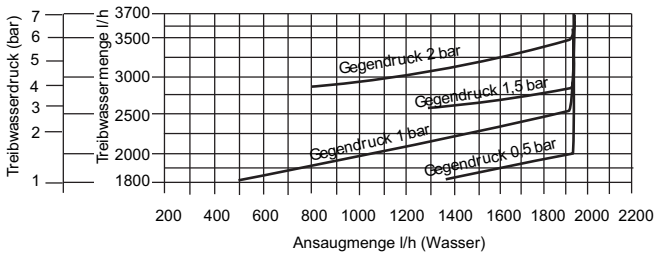

DN40, nozzle size 3.5

DN40, nozzle size 3.5

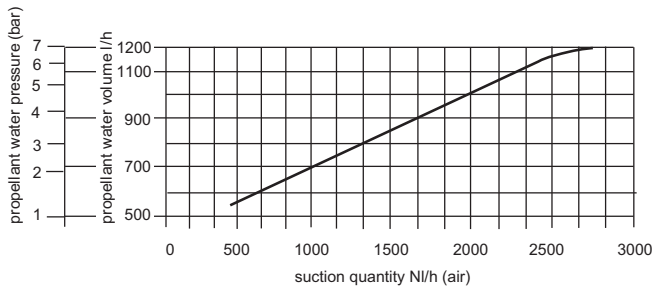
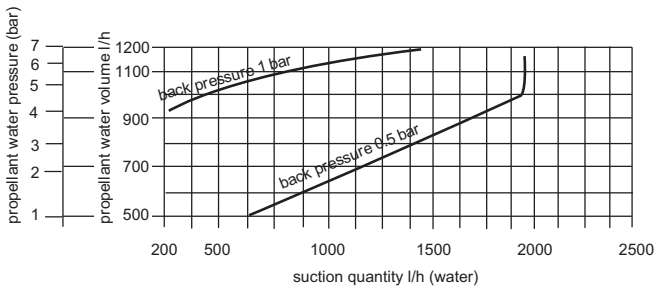

# Water Jet Suction Pump Type P20

## Suction medium: water

### DN40, nozzle size 5.5

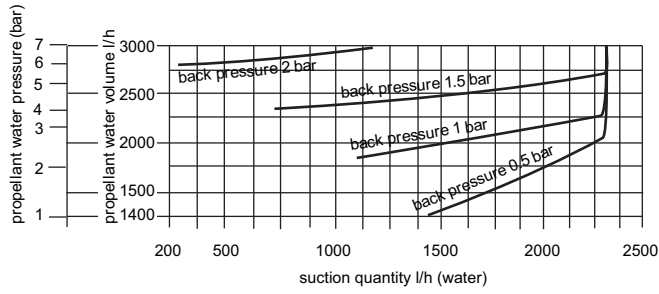

## Suction medium: air

### DN40, nozzle size 5.5

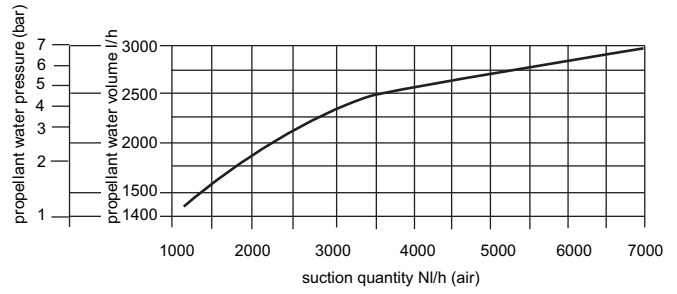

### DN40, nozzle size 7.5

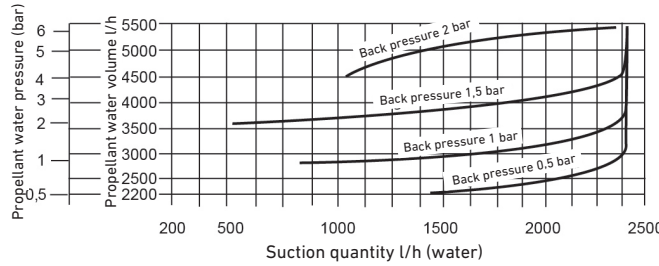

### DN40, nozzle size 7.5

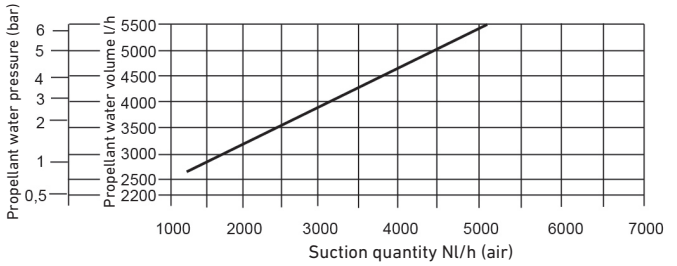

### DN50, nozzle size 5.0

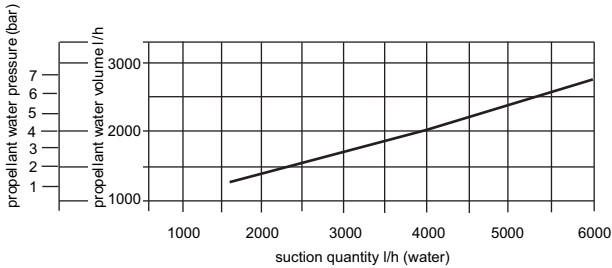

### DN50, nozzle size 5.0

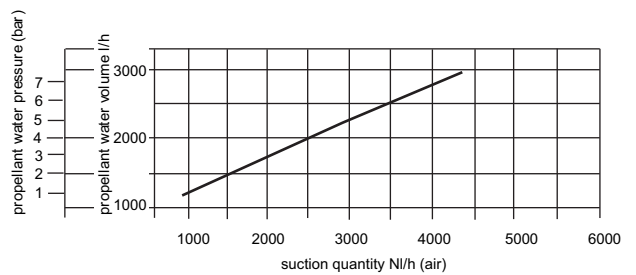

### DN50, nozzle size 7.0

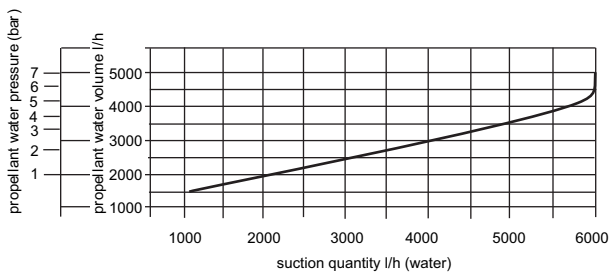

### DN50, nozzle size 7.0

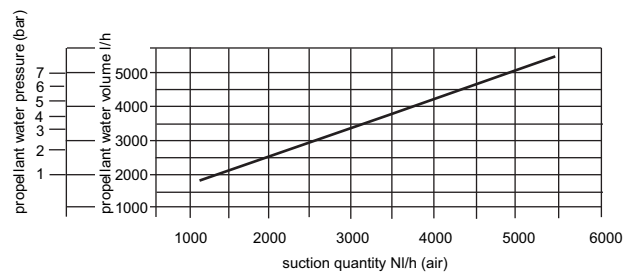

### DN50, nozzle size 9.0

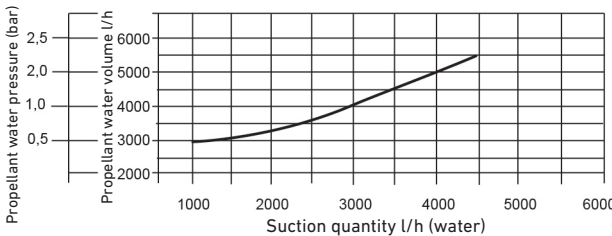

### DN50, nozzle size 9.0

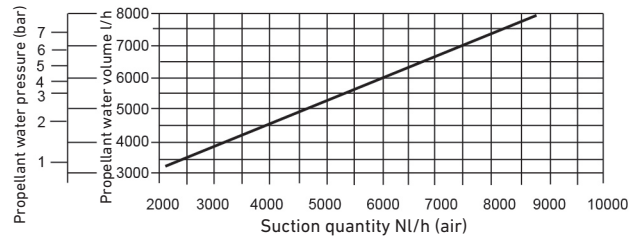

Suction medium: water

Suction medium: air

DN65, nozzle size 6.5

DN65, nozzle size 6.5

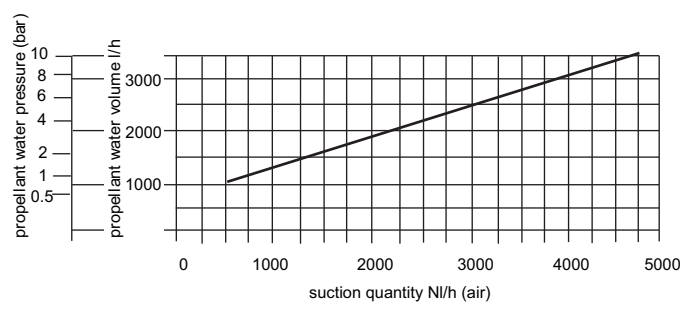
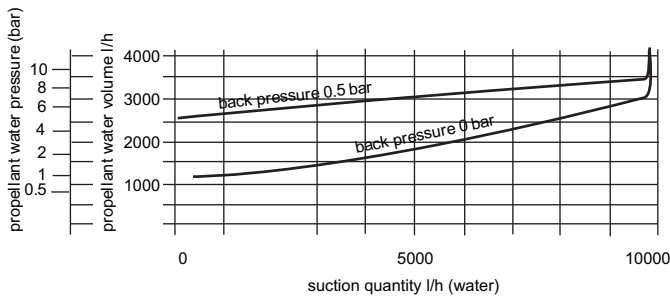

DN65, nozzle size 9.0

DN65, nozzle size 9.0

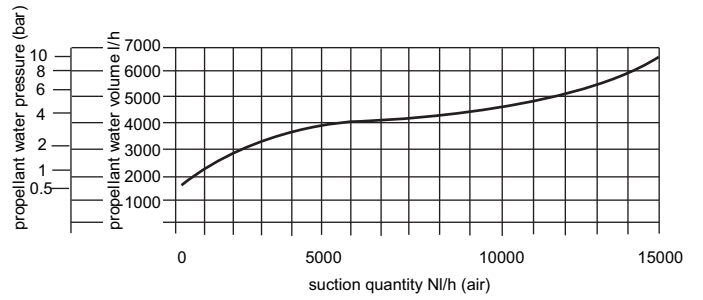
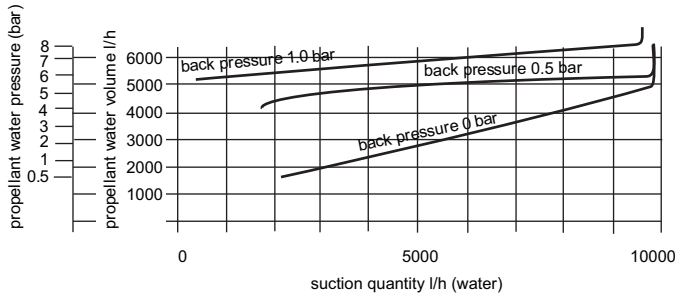

DN65, nozzle size 11.5

DN65, nozzle size 11.5

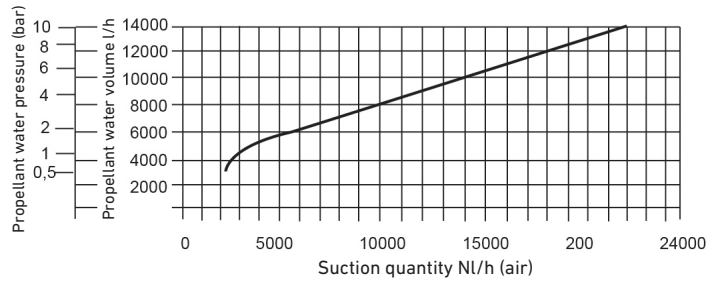
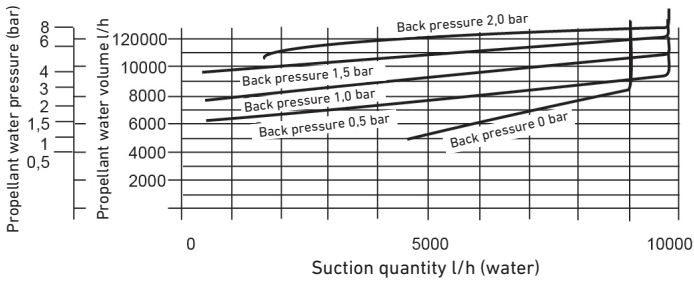

DN80, nozzle size 8.0

DN80, nozzle size 8.0

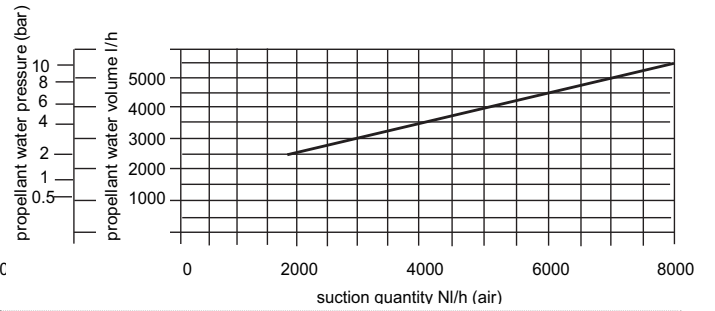
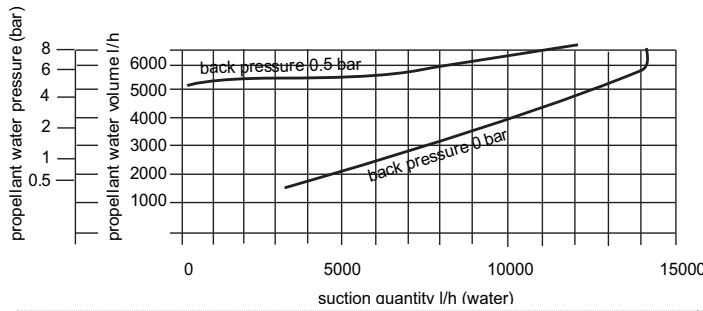

DN80, nozzle size 11.0

DN80, nozzle size 11.0

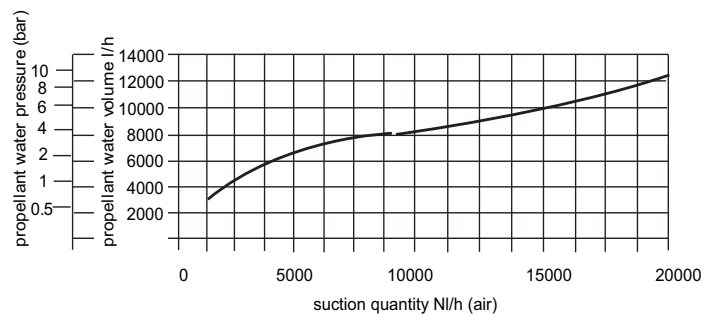
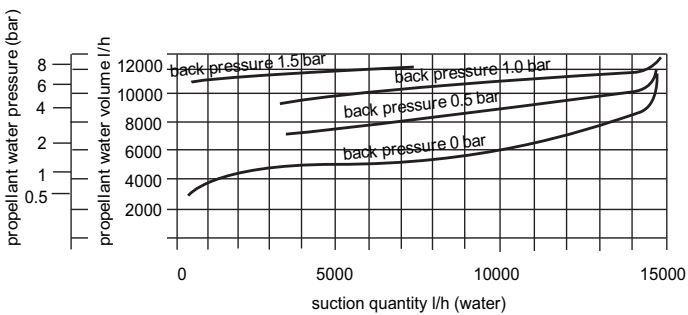

Suction medium: water

DN80, nozzle size 14.0

Suction medium: air

DN80, nozzle size 14.0

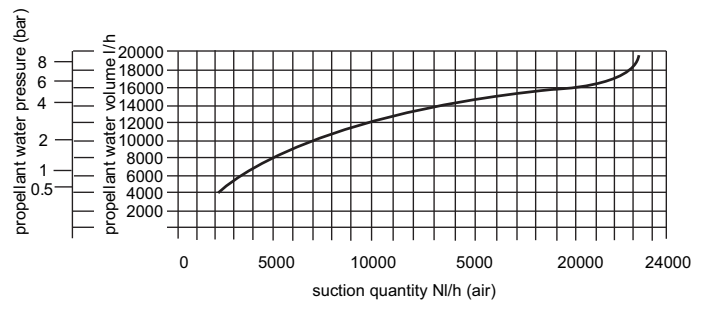
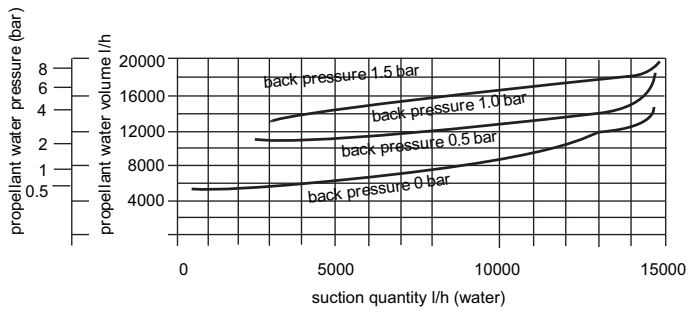



The GF Gauge Guard Type Z500/ Z501 is designed to measure pressure of neutral and aggressive media. The pressure gauge is separated from the medium by a TFM coated EPDM backing diaphragm. Pressure from the pipe/medium side will be transmitted by a buffer fluid.

The large diaphragm surface and the incompressibility of the buffer fluid allow a high accurate pressure transmission. The wide range of connections and possible materials.

## Features

- All medium wetted parts are made of highly resistant plastic
- No direct contact from pressure gauge to medium
- Gauge guard maintenance-free
- Independent installation position
- Large surface diaphragm provides high accuracy
- The unique coupling nut design impedes any torsion on the diaphragm that guarantees a high precision pressure transmission
- The new design assures a uniform sealing pressure on the diaphragm
- Various pipe connection options are available by just a change of the base part

## Applications

- Chemical Processing Industry
- Water Treatment
- Energy
- Marine

# Specifications

Pressure Rating	
PN	10 @ 20 °C
	150 psi @ 68 °F
Materials Gauge Guard	
Upper Part & Union	PP GF30
Lower Part	PVC-U, PP-H, PVDF
Diaphragm	EPDM/TFM
Buffer-fluid	Glysantine (DI water on request)
Interfaces Gauge Guard	
Pressure Gauge Connection	G1/4" for d25 G1/2" for d32
Pipe Connection	Depending on material welding or cementing spigot for socket connection with female inner thread d25 with G1/4" inner thread d32 with G1/2" inner thread Butt fusion spigot or cementing spigot on request
Pressure Gauge	
Pressure Range	0-10 bar (0-150 psi) 0-6 bar (0-90 psi)
Pressure Gauge Material	Plastic housing with brass connector CrNi housing with CrNi connector
Gauge Threads and Size	R1/4" d63 mm R1/2" d100 mm

# Dimensions

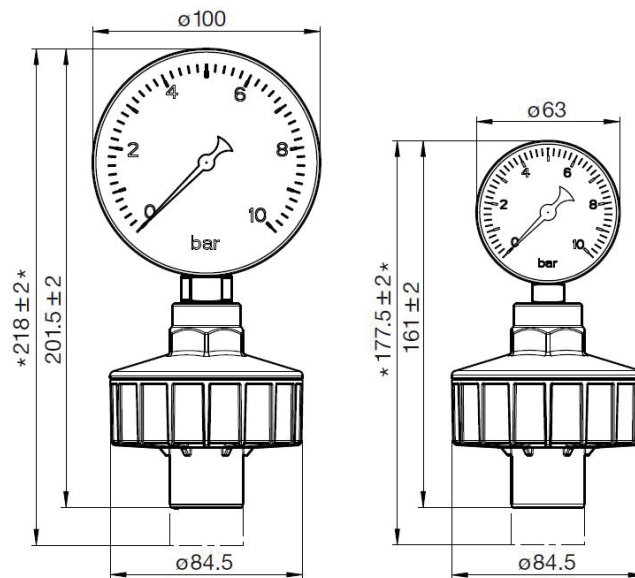



## Connections

Threaded female Connections (Standard)

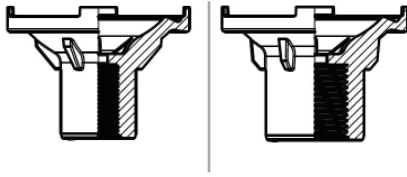

G1/2"

PP

PVC

PVDF

G1/4"

PP

PVD

PVDF

Threaded female Connections and Spigots (Optional)

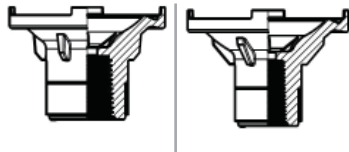

NPT 1/2"

PP

PVC

PVDF

NPT 1/4"

PP

PVC

PVDF

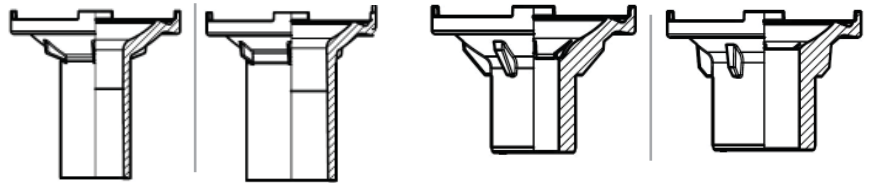

d25

PP  
PVDF

d32

PP  
PVDF

d25

PVC

d32

PVC

## Assembly and Handling

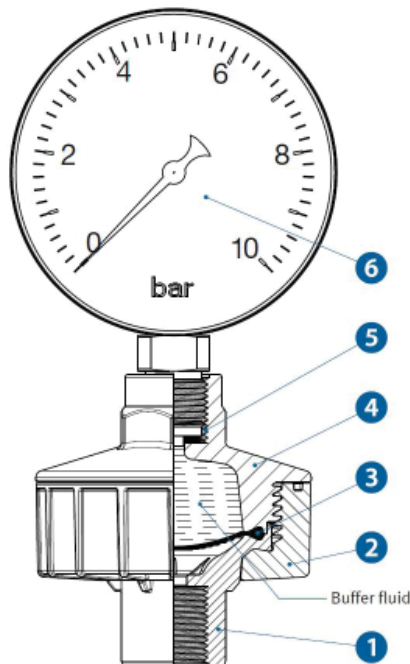

Item	Description
1	Lower part (PP, PVC and PVDF)
2	Union nut
3	Diaphragm EPDM/TFM
4	Upper Part (PP GF)
5	Pressure Gauge Seal
6	Pressure Gauge

### Filling the buffer fluid

- Upper body (Item 4) of the gauge guard Z500/ Z501-fill preferably with Glysantine, or distilled water up to the lower edge of the threaded socket.
- Move smoothly (up and down) the diaphragm from below using a blunt object until no more air bubbles appear
- Screw in the pressure gauge
- If the pressure gauge already displays a pressure, some buffer fluid has to be removed until there is no pressure showing anymore

## Installation instructions

We recommend installing the gauge guard in a vertical position with a previous screwed connection and an isolating device. This ensures that the pressure gauge can be brought into the desired reading position and allows for easy replacement if needed.

## Ordering Information

Type	GF Code	Pipe con. OD	Pipe Thread	Manometer con.	Material	Pressure Range	Manometer Mat.
Z501	199 042 000	d25	G1/4"	G 1/4"	PVC	No gauge	-
Z501	199 042 001	d32	G1/2"	G 1/2"	PVC	No gauge	-
Z501	199 042 100	d25	G1/4"	G 1/4"	PP-H	No gauge	-
Z501	199 042 101	d32	G1/2"	G 1/2"	PP-H	No gauge	-
Z501	199 042 200	d25	G1/4"	G 1/4"	PVDF	No gauge	-
Z501	199 042 201	d32	G1/2"	G 1/2"	PVDF	No gauge	-
Z500	199 042 010	d25	G1/4"	G 1/4"	PVC	0 - 10 bar	Brass
Z500	199 042 011	d32	G1/2"	G 1/2"	PVC	0 - 10 bar	Brass
Z500	199 042 030	d25	G1/4"	G 1/4"	PVC	0 - 6 bar	Brass
Z500	199 042 031	d32	G1/2"	G 1/2"	PVC	0 - 6 bar	Brass
Z500	199 042 020	d25	G1/4"	G 1/4"	PVC	0 - 10 bar	Stainless steel
Z500	199 042 040	d25	G1/2"	G 1/4"	PVC	0 - 6 bar	Stainless steel
Z500	199 042 110	d25	G1/4"	G 1/4"	PP-H	0 - 10 bar	Brass
Z500	199 042 111	d32	G1/2"	G 1/2"	PP-H	0 - 10 bar	Brass
Z500	199 042 130	d25	G1/4"	G 1/4"	PP-H	0 - 6 bar	Brass
Z500	199 042 131	d32	G1/2"	G 1/2"	PP-H	0 - 6 bar	Brass
Z500	199 042 120	d25	G1/4"	G 1/4"	PP-H	0 - 10 bar	Stainless steel
Z500	199 042 140	d25	G1/2"	G 1/4"	PP-H	0 - 6 bar	Stainless steel
Z500	199 042 210	d25	G1/4"	G 1/4"	PVDF	0 - 10 bar	Brass
Z500	199 042 211	d32	G1/2"	G 1/2"	PVDF	0 - 10 bar	Brass
Z500	199 042 230	d25	G1/4"	G 1/4"	PVDF	0 - 6 bar	Brass
Z500	199 042 231	d32	G1/2"	G 1/2"	PVDF	0 - 6 bar	Brass
Z500	199 042 220	d25	G1/4"	G 1/4"	PVDF	0 - 10 bar	Stainless steel
Z500	199 042 240	d25	G1/2"	G 1/4"	PVDF	0 - 6 bar	Stainless steel